

Bearings for Steel Industry

NSK high performance bearings help to maximize uptime and to reduce maintenance costs for steel manufacturers.

Choose
NSK





NSK solutions for iron and steel works

NSK high performance bearings meet the requirements of steel manufacturers.

Our years of field experience, product development and accumulated technologies have allowed us to deploy a range of techniques for boosting the productivity of steel manufacturing plant.



NSK is the world's top supplier of bearings to iron and steel works

Headquarters

- Japan
 - Tokyo
- North and South America
 - Ann Arbor
- Europe
 - Maidenhead
- Asia
 - Shanghai
 - Singapore

Technical offices

- Japan
 - Fujisawa
 - Maebashi
- North and South America
 - Ann Arbor
- Europe
 - Newark
 - Kielce
- Asia
 - Kunshan

Plants

- Japan
 - Fujisawa
 - Hanyu
 - Otsu
 - Konan
 - Takasaki
 - Haruna
 - Maebashi
 - Tanakura
 - Ukiha
- North America
 - Ann Arbor
 - Clarinda
 - Franklin
 - Liberty
 - Bennington
- South America
 - Suzano
- Europe
 - Peterlee
 - Newark
 - Kielce
 - Munderkingen
 - Torino
- Asia
 - Kunshan
 - Anshun
 - Dongguan
 - Zhangjiagang
 - Suzhou
 - Changshu
 - Chennai
 - Jakarta
 - Changwon
 - Balakong
 - Chonburi
 - Chachoengsao

Sales offices

- Japan
 - Tokyo
 - Nagoya
 - Osaka
 - 27 other offices
- North America
 - Ann Arbor
 - Indianapolis
 - Chicago
 - San Jose
 - Los Angeles
 - Bennington
 - Miami
 - Atlanta
 - Montreal
 - Toronto
 - Vancouver
- South America
 - Buenos Aires
 - Sao Paulo
 - Belo Horizonte
 - Joinville
 - Porto Alegre
 - Recife
 - Mexico City
- Europe
 - Maidenhead
 - Newark
 - Coventry
 - Paris
 - Dusseldorf
 - Stuttgart
 - Leipzig
 - Milano
 - Tilburg
 - Barcelona
 - Warsaw
 - Istanbul

Africa

- Johannesburg

Asia

- Beijing
- Shanghai
- Guangzhou
- Anshun
- Chengdu
- Hong Kong
- Taipei
- Taichung
- Tainan
- Seoul
- Chennai
- Jakarta
- Manila
- Bangkok
- Kuala Lumpur
- Prai
- Johor Bahru
- Kota Kinabalu
- Singapore

Oceania

- Melbourne
- Sydney
- Brisbane
- Adelaide
- Perth
- Auckland



NSK bearings for the iron and steel industry are created by our global research and development system.

NSK has engaged in technological challenges for many years, working with customers in the iron and steel industry around the world to develop effective solutions.

We have developed high performance products for the iron and steel industry through strengthening our global R&D focus. We continue to create top of the line products that utilize the core technologies of lubrication, materials, and analytical techniques to respond to field requirements.

Chronology of Product Development

● New products ● New material ● New lubrication

Year	Bearings for Continuous Casting Machines	Bearings for Rolling Mills	Bearings for Other Equipments in Iron and Steel Works
2000	<ul style="list-style-type: none"> ● SWR Bearings ● Tapered Roller Bearings with Aligning Rings 	<ul style="list-style-type: none"> ● Water-TF Roll Neck Bearings ● Extra-Capacity Sealed-Clean Roll Neck Bearings 	<ul style="list-style-type: none"> ● SNN Plummer Blocks ● Molded-Oil Bearings for Iron and Steel Works
1995		<ul style="list-style-type: none"> ● High-Capacity Sealed-Clean Roll Neck Bearings ● Stud-Type Four-Row Cylindrical Roller Bearings 	<ul style="list-style-type: none"> ● Super-TF Roll Neck Bearings
1990	<ul style="list-style-type: none"> ● Oil-Air Lubricators with Malfunction Detection System 		<ul style="list-style-type: none"> ● Sizing Press Bearings
1985	<ul style="list-style-type: none"> ● Cylindrical Roller Bearings with Aligning Rings 	<ul style="list-style-type: none"> ● New Type Bearings for New Developed Rolling Mills 	<ul style="list-style-type: none"> ● Sealed-Clean Bearings for Inboard Rollers of Sintering Machine Pallets ● Split Bearings for BOFs and Converter Trunnions
1980	<ul style="list-style-type: none"> ● Split Bearing Units ● Sealed-Clean Spherical Roller Bearings 	<ul style="list-style-type: none"> ● Exclusive Grease for Sealed Bearings ● Sealed-Clean Roll Neck Bearings 	<ul style="list-style-type: none"> ● Sealed-Clean Bearings for Chain Conveyors ● Sealed-Clean Bearings for Pallet Wheels of Sintering Machine Pallets ● Leveller Units

Development of Steel Bearings

● NSK technologies support the development of bearings for iron and steel works

Design technology	Evaluation technology	Analysis and diagnostic technologies
<ul style="list-style-type: none"> ● Automatic design system for integrating analysis and field experience ● Design for applications utilizing newly developed materials with longer service life for use under harsh conditions (such as materials resistant to debris, water, and wear) 	<ul style="list-style-type: none"> ● Field simulation techniques <p>Performance and endurance evaluation test rigs utilizing actual-size bearings</p>	<ul style="list-style-type: none"> ● Bearing analysis technology ● Fatigue analysis technology ● Diagnostic technology



Tester for bearings used in guide rolls of continuous casting machines



Tester for bearings used in backup rolls of rolling mills



Tester for bearings used in work rolls of rolling mills

● Four core technologies supporting the product development of NSK

Tribology	Material technology	Analytical technology	Motion and control
<ul style="list-style-type: none"> ● Lubrication theory ● Life theory ● Surface analysis ● Surface modification 	<ul style="list-style-type: none"> ● Bearing steel ● Heat treatment ● Ceramics ● Polymeric materials 	<ul style="list-style-type: none"> ● NSK-BRAIN ● Simulation technology ● Computer analysis 	<ul style="list-style-type: none"> ● System technology ● Sensing technology ● Motor technology

A complete product line for all steel mill processes delivers improved productivity and lowered maintenance costs, with long life and highly reliable bearings.

Bearings for iron and steel works operate under a variety of harsh conditions, including high temperatures, high speed or super low speed operation, as well as environments contaminated with water and debris. NSK products support the stable operation of equipment under the toughest conditions.

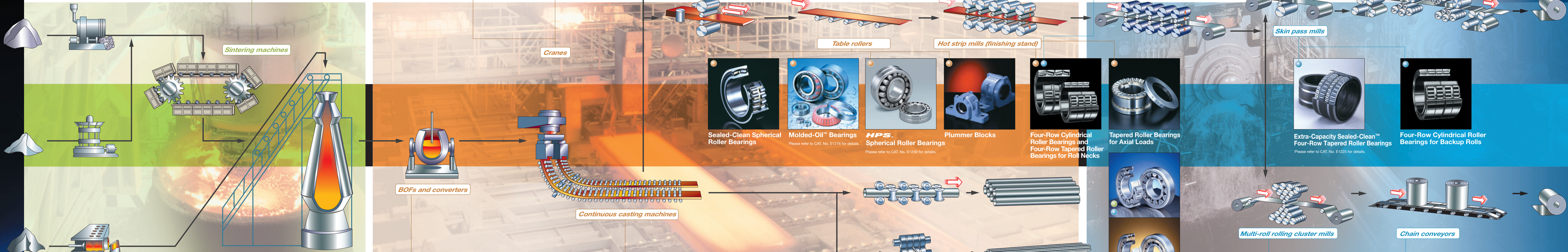

Sealed-Clean Bearings for Sintering Machine Pallets



Full-Complement Cylindrical Roller Bearings for Crane Sheaves
Please refer to CAT. No. E1218 for details.



Full-Complement Cylindrical Roller Bearings for Crane Sheaves
Please refer to CAT. No. E1206 for details.



Four-Row Cylindrical Roller Bearings for Backup Rolls (with stud-type cages for super heavy loads)

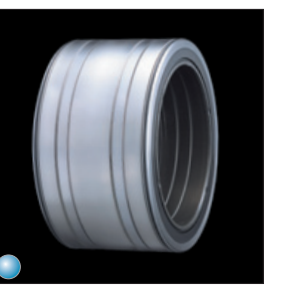

WTF® Bearings
Please refer to CAT. No. E1251 for details.



Extra-Capacity Sealed-Clean™ Four-Row Tapered Roller Bearings
Please refer to CAT. No. E1225 for details.



Double-Row Tapered Roller Bearings for Axial Loads

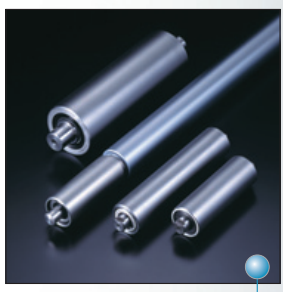

Bearing Units for Tension Levellers
Please refer to CAT. No. E395 for details.

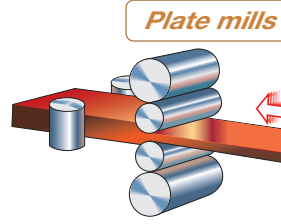
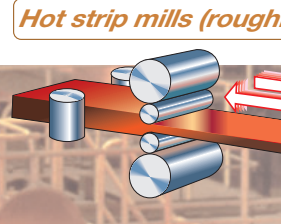

Plate mills



Hot strip mills (roughing stand)



Table rollers

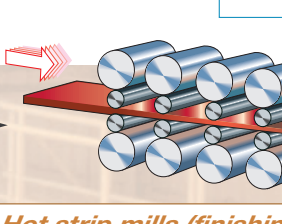

Hot strip mills (finishing stand)

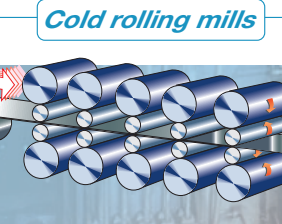

Cold rolling mills

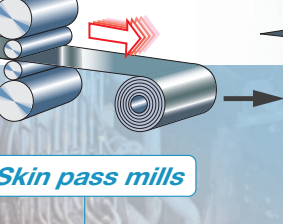

Skin pass mills

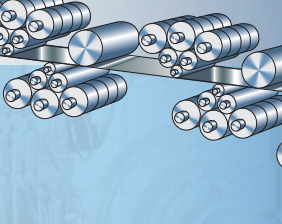

Tension levellers

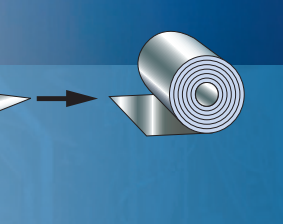

Chain conveyors

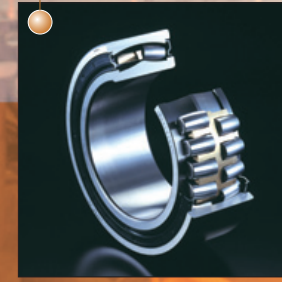

Sealed-Clean Spherical Roller Bearings



Molded-Oil™ Bearings
Please refer to CAT. No. E1216 for details.



HPS Spherical Roller Bearings
Please refer to CAT. No. E1259 for details.

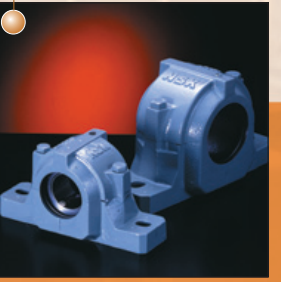

Plummer Blocks



Four-Row Cylindrical Roller Bearings and Four-Row Tapered Roller Bearings for Roll Necks



Tapered Roller Bearings for Axial Loads



Extra-Capacity Sealed-Clean™ Four-Row Tapered Roller Bearings
Please refer to CAT. No. E1225 for details.



Four-Row Cylindrical Roller Bearings for Backup Rolls

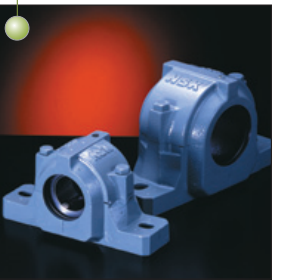

Plummer Blocks



HPS Spherical Roller Bearings
Please refer to CAT. No. E1259 for details.



Ultra-Large Split Bearings for BOFs and Converter Trunnions



Tapered Roller Bearings with Aligning Rings



Cylindrical Roller Bearings with Aligning Rings
Please refer to CAT. No. E390 for details.



Split Roller Bearing Units for Segmented Rolls
Please refer to CAT. No. E390 for details.



SWR™ Bearings
Please refer to CAT. No. E1242 for details.



Four-Row Tapered Roller Bearings for Vertical Rolls

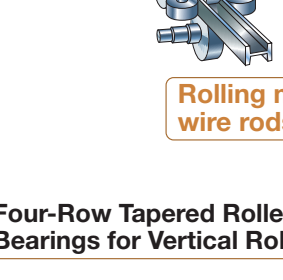

Rolling mills for steel pipes, steel bars, wire rods and sections

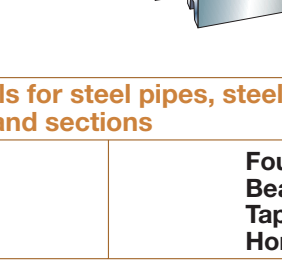

Four-Row Cylindrical Roller Bearings and Four-Row Tapered Roller Bearings for Horizontal Rolls



High-Capacity Cylindrical Roller Bearings EW, EM Series
Please refer to CAT. No. E1238 and No. E1237 for details.



Backing Bearings for Backup Rolls

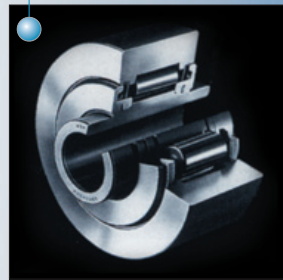

S-Type Sealed-Clean Bearings for Chain Conveyors

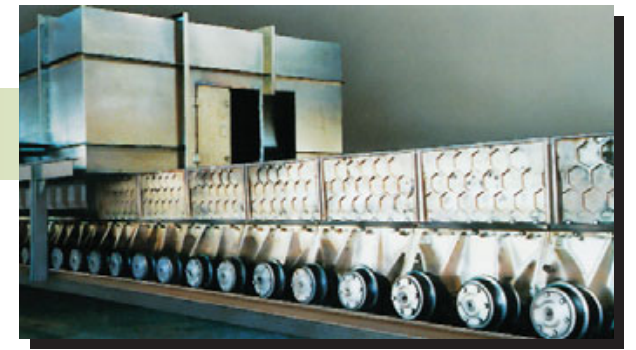

Benefits

- 1 Stable machinery operation through higher reliability and longer operating life
- 2 Cleaner areas adjacent to equipment
- 3 Reduced maintenance costs

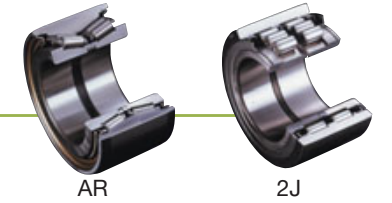

1. Operating conditions

- High temperature
- Heavy loads
- Low speed
- Scale (sintered particles)

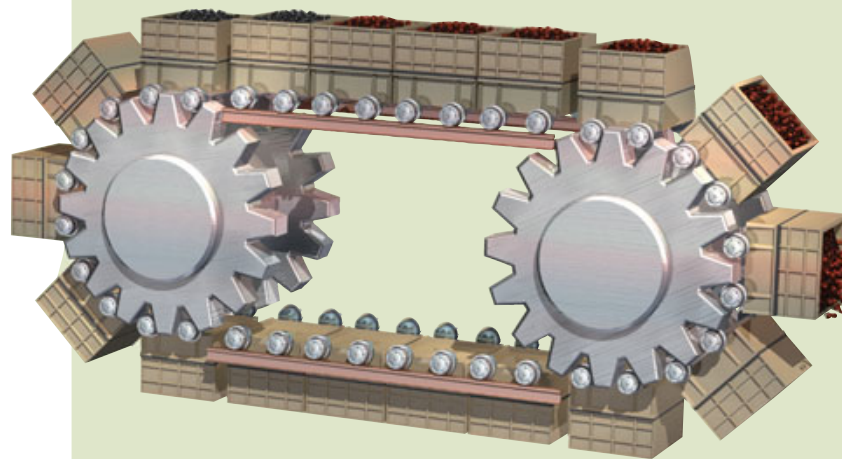

Sintering equipment

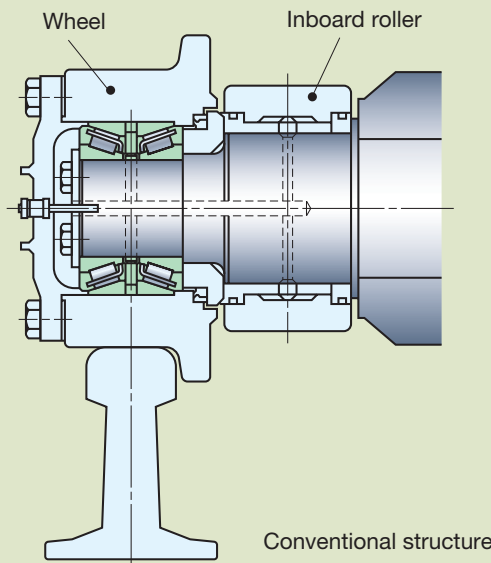

Conventional structure

2. Problems

Typical problems of bearings for sintering equipment

Problem 1

Premature failure of bearings for pallet wheels and bearings for inboard rollers (plain bearings)

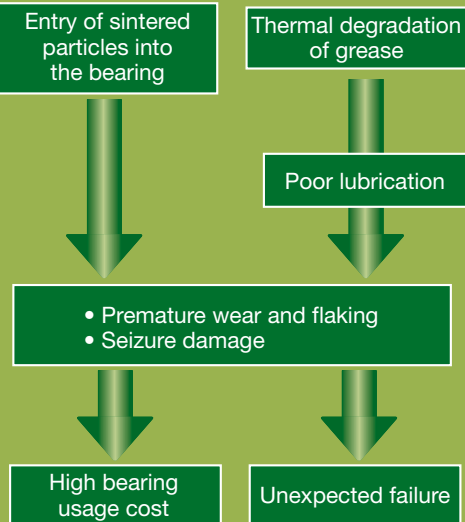

Problem 2

Contamination around the equipment, high maintenance costs

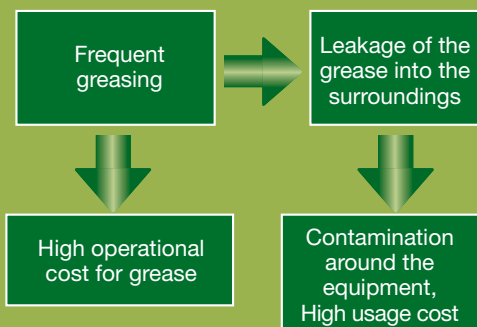

3. Countermeasures

Design measures

Features Sealed-Clean Bearings for Pallet Wheels—AR Series

- Optimum crowning of the roller raceway surface enabling resistance to unbalanced load of wheels
- High sealing performance (featuring a special contact seal)
- Packing of grease with excellent heat and pressure resistance
- Easier handling (one-piece design with fastening ring adopted for the inner ring)

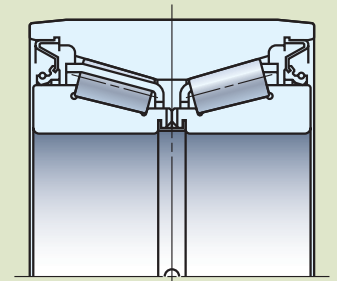

Design measures

Features Sealed-Clean Bearings for Inboard Rollers—2J Series

- Higher load capacity (by outer ring thickness design with high strength and full-complement roller type)
- Improvement of axial load capacity
- High sealing performance (featuring a special contact seal)
- Packing of grease with excellent heat and pressure resistance
- Easier handling (one-piece design with fastening ring adopted for the inner ring)

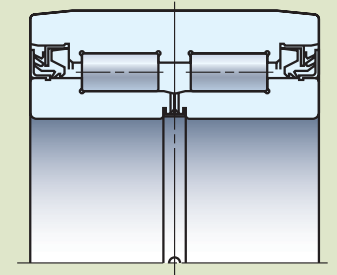

• Durability Performance of Bearings in Field Test

	Comparison of actual life extension in field tests		
Conventional structure	1		
Newly developed structure	2.5 on average		3 at maximum

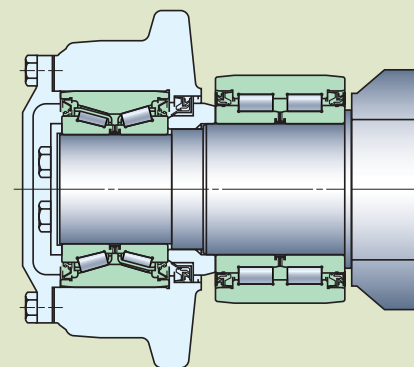

Newly developed structure



Estimated effect of maintenance cost reduction

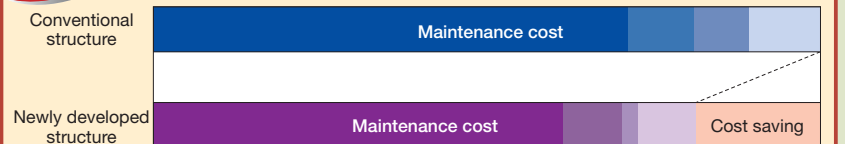

The maintenance cost includes the replacement costs for bearings, seals, and grease and the operational costs associated with the bearing replacement and greasing.

If the bearing life extends 2.5 times on average as a result of using the newly developed structure for bearings for pallet wheels/inboard rollers for pallet dollies, the total maintenance cost reduction effect is estimated to be 25% to 35%.

Bearing Series	AR Series	2J Series
Bearing No.		



Benefits

- 1 Bearings can be replaced without removing the bull gear, thus reducing maintenance costs
- 2 Reduction of maintenance costs by shortening length of time for bearing replacement work
- 3 Reduction of production loss, which would affect subsequent processes

1. Operating conditions

High temperature

Heavy loads

Ultra-low speed and Rocking

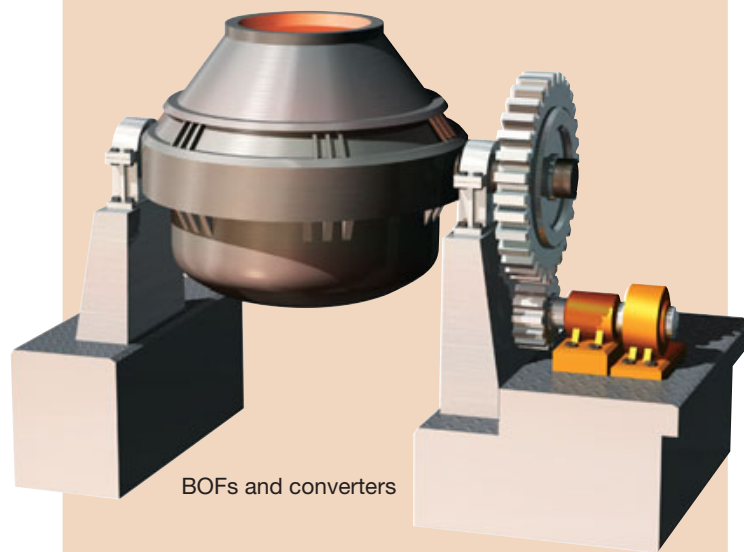

BOFs and converters

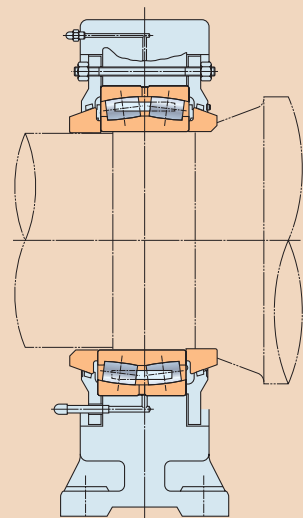

Conventional structure

2. Problems

Typical problems of bearings for BOFs and converters

Inboard bearings cannot be replaced without removing the bull gear

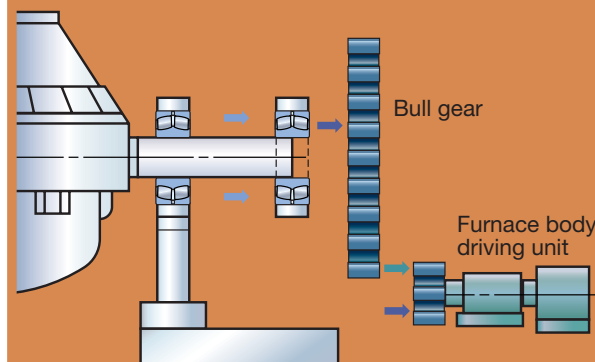

Bearing replacement work is time-consuming, requiring high maintenance costs

In addition, sudden bearing replacement due to an unexpected failure causes large production loss in the subsequent processes

3. Countermeasures

Design measures

Features Ultra-Large Split Bearings for BOFs and Converter Trunnions

- A split design of ultra-large spherical roller bearings: (1) outer ring (2) inner ring (3) roller and cage assembly and (4) fastening ring
- Seal sliding surface integrated by a fastening ring

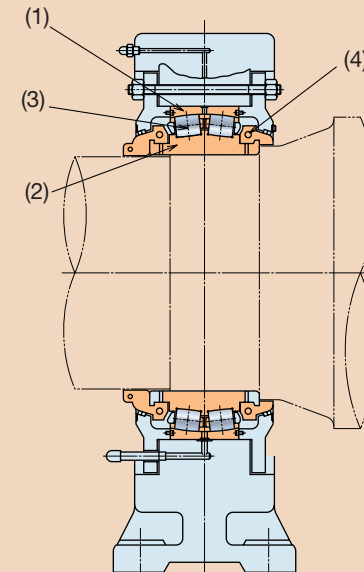

Newly developed structure

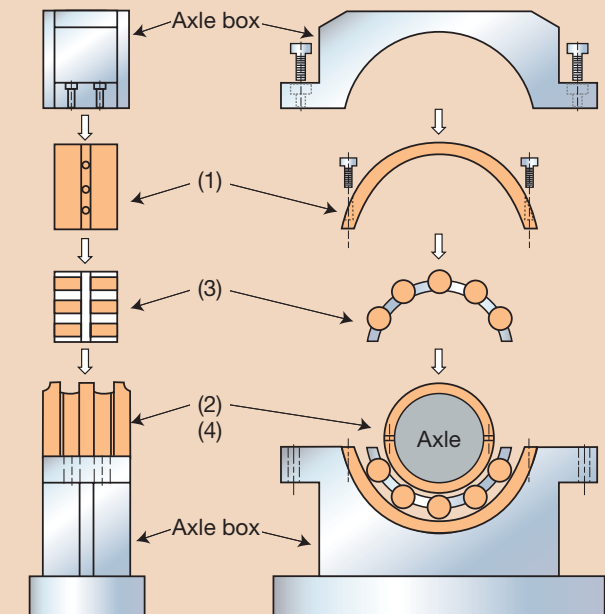

Image of bearing mounting

User Benefit

Maintenance cost reduction effect

Result of the comparison of time required for bearing replacement work

Bearing type	Comparison of time required for bearing replacement work in field test	
Conventional structure (one-piece type)	1	
Newly developed structure (split type)	0.65	0.35 ← Period shortening

• The bearing replacement period represents the actual result for bearings with bore diameter of 1 200 mm to 1 400 mm.

• In the case above, the bearing with the newly developed structure reduced the time needed for bearing replacement work by approximately 35%, and thereby significantly reduced maintenance cost.



Benefits

- 1 Improved bearing durability prevents unexpected accidents
- 2 Roll segment is replaced less frequently, thus reducing maintenance costs

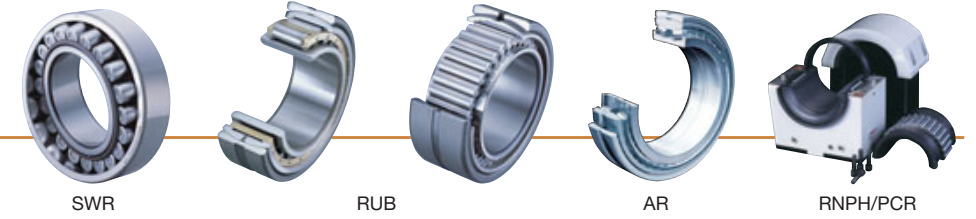

1. Operating conditions

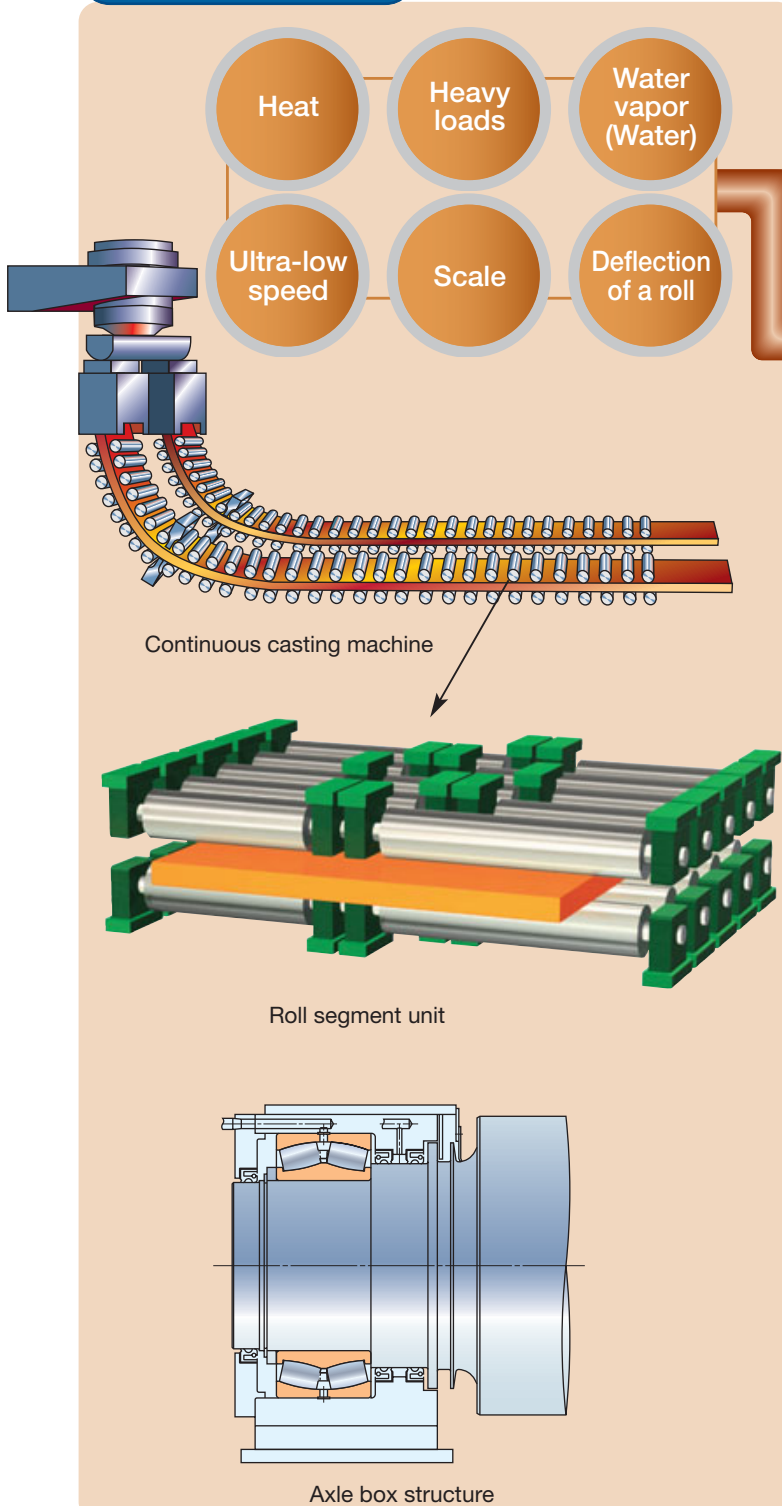

2. Problems

Typical problems of bearings for continuous casting machines



3. Countermeasures

Material measures

- Comprehensive measures to improve performance of spherical roller bearings for continuous casting machines
- SWR Bearings solve wear problems and significantly extend operating life

Features SWR™ Bearings (Spherical Roller Bearings) – SWR Series

- Improved wear resistance → Three times compared to AISI 52100 bearing steel
- Improved flaking life property → Five times compared to AISI 52100 bearing steel
- Improved toughness of material core (prevention of crack damage) → Five times compared to AISI 52100 bearing steel

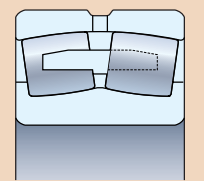

Design measures

- Self-centering function added to non-sliding bearing types (cylindrical, tapered).
- Solution of wear problems for conventional spherical roller bearing allows significantly longer operating life

Features Cylindrical Roller Bearings with Aligning Rings (for free end) – RUB Series

- Prevention of wear due to differential sliding of spherical roller bearing and addition of self-aligning function
- Smooth relief of roll expansion
- Type: Easy handling cage type Full-complement type with higher load capacity

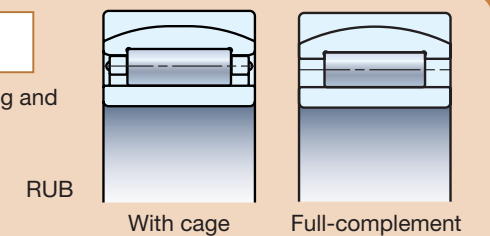

Features Tapered Roller Bearings with Aligning Rings (for fixed end) – AR Series

- Prevention of wear due to differential sliding of spherical roller bearing and addition of self-aligning function
- High thrust load capacity

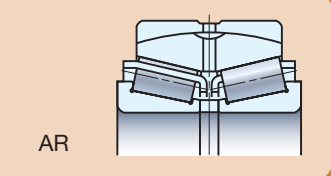

Features Split Cylindrical Roller Bearings (for segmented rolls) – RNP/PCR Series

- Prevention of wear due to differential sliding of spherical roller bearing and addition of self-aligning function
- Full-complement, higher load capacity design
- Multi-functional seal and high rigidity plummer block unit

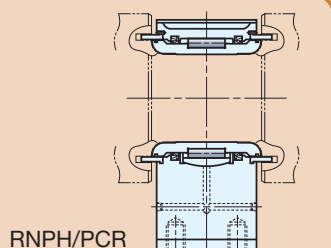

For detailed technical information and user benefit of SWR/RUB/AR/RNP series: Page 17-18

Bearing Series	SWR Series	RUB Series	AR Series	RNPH / PCR Series
Bearing No.	Page 27-28	Page 29	Page 30	Page 31-32
Recommended bearing arrangement	Page 15-16			

Recommended Bearing Arrangements

NSK has prepared the following arrangements for bearings used in guide rolls of continuous casting machines with recently developed SWR Bearings and tapered roller bearings with aligning rings additionally.

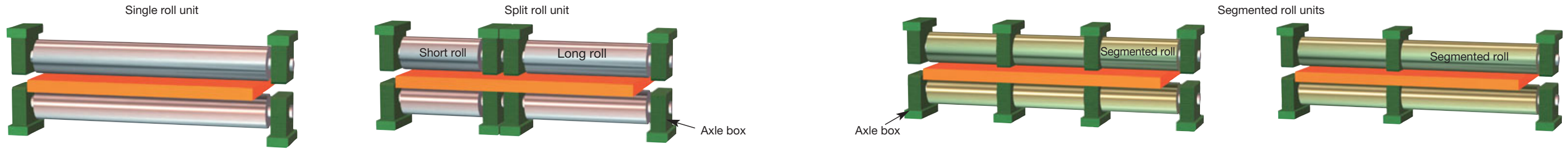

CASE 1 Spherical roller bearings currently used can be replaced with SWR Bearings without modifying the axle boxes, thus easily enhancing performance:

- Bearing arrangement for single rolls and split rolls

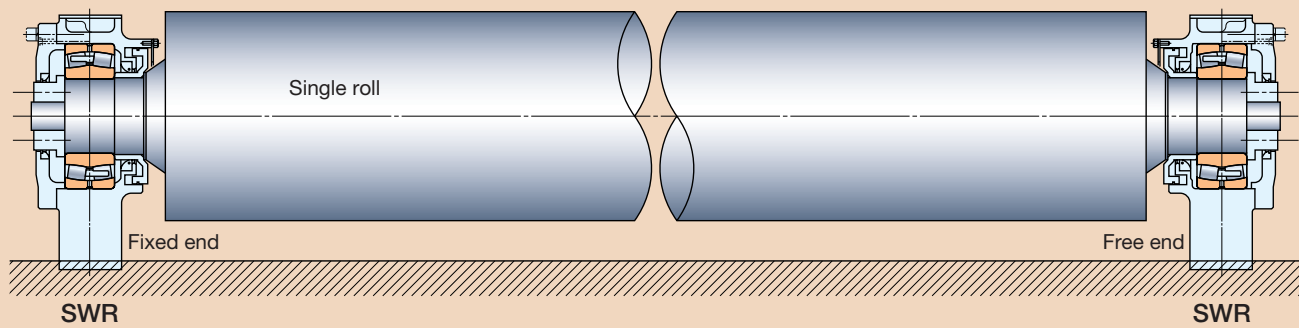

- Bearing arrangement for segmented drive rolls

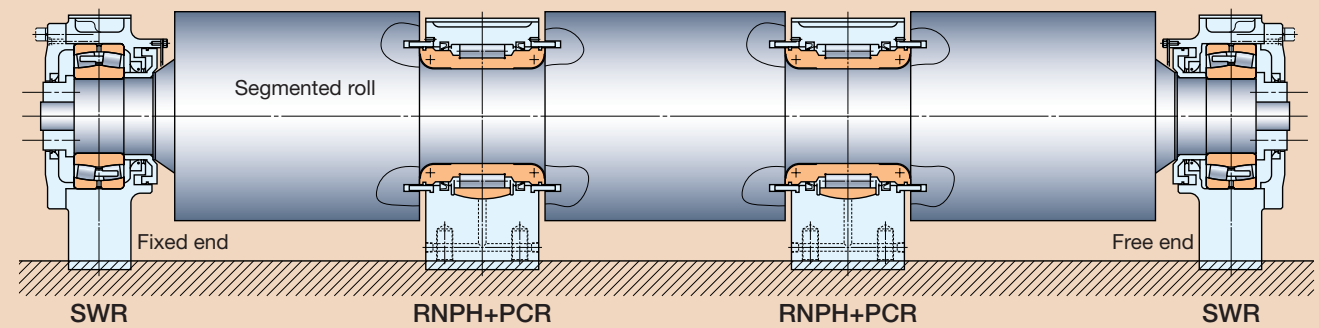

CASE 2 Optimal bearing arrangement to relieve roll expansion:

- Bearing arrangement for single rolls and split rolls

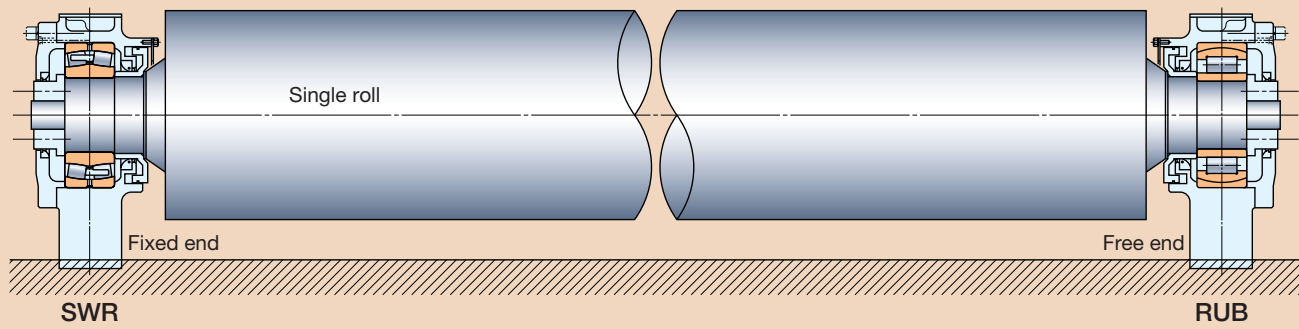

- Bearing arrangement for segmented drive rolls

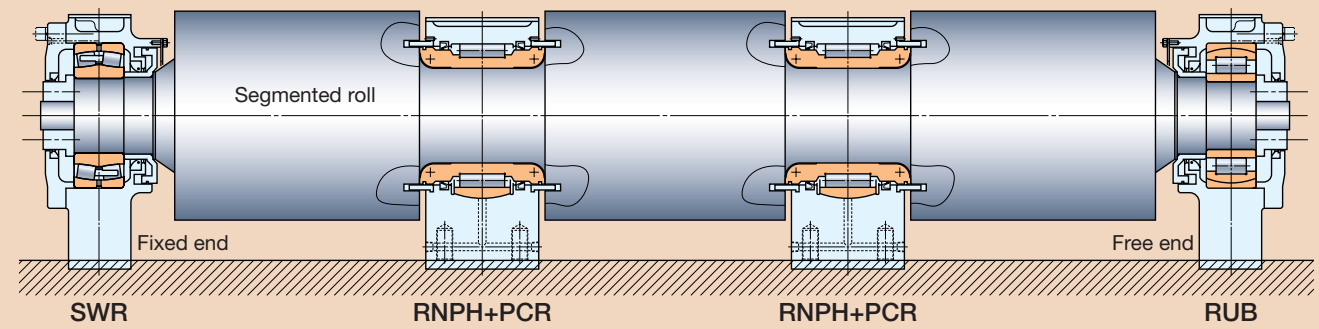

The structure in the axle box needs to be partially modified in case of changing the free-end bearing from a spherical roller bearing to RUB.

CASE 3 Bearing arrangement to prevent roll expansion and roll thrust load:

- Bearing arrangement for single rolls and split rolls

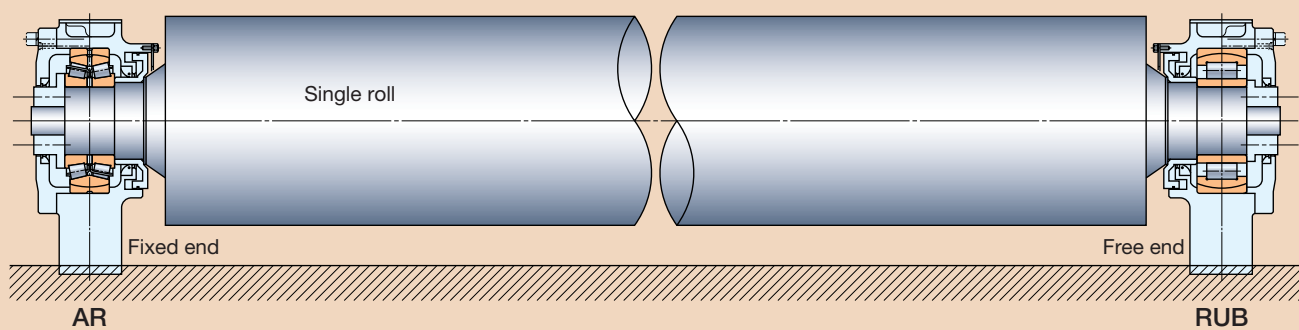

- Bearing arrangement for segmented drive rolls

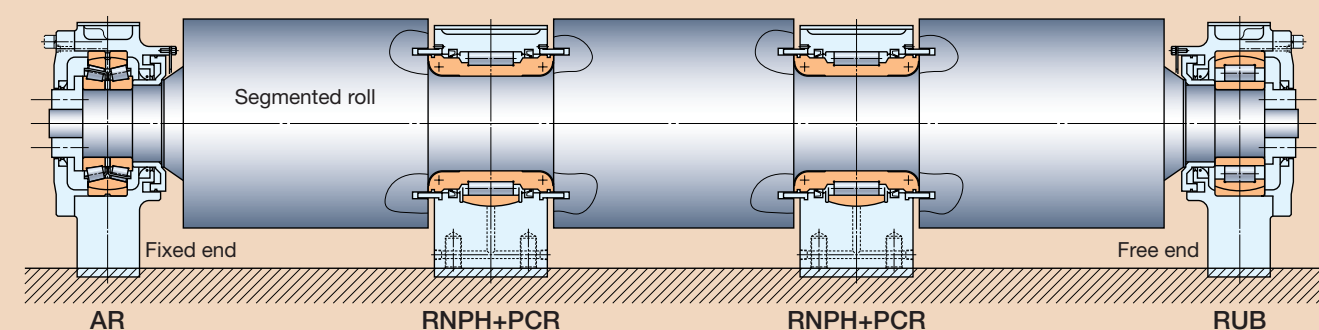

The structure in the axle box needs to be partially modified in case of changing the fixed- and free-end bearings from spherical roller bearings to AR and RUB.

Contribution to Enhancement of Reliability and Reduction of Maintenance Costs for Continuous Casting Machines

Identification of the failure mechanism

Failure mechanism of spherical roller bearings for continuous casting machines

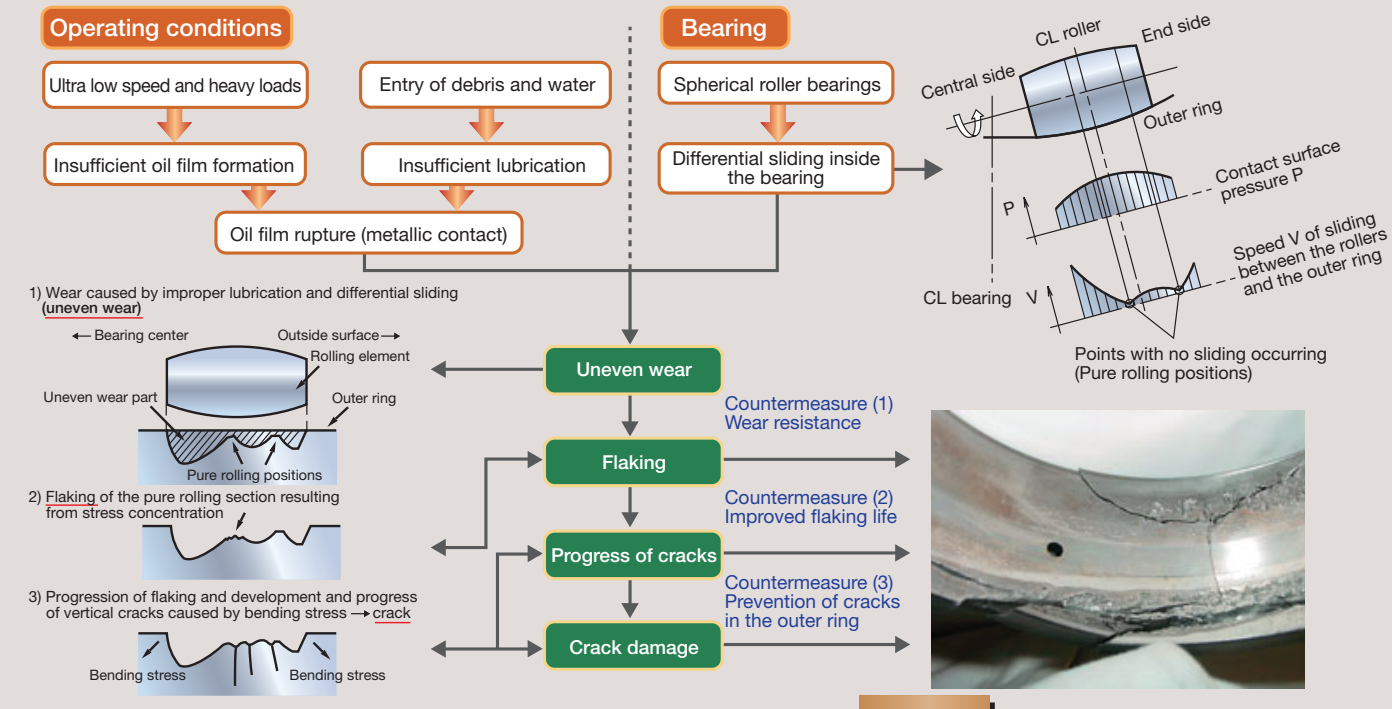

Material measures

Selection of steel chemical composition



<p>Development of wear-resistant materials</p> <ul style="list-style-type: none"> Selection of steel chemical composition Applied special heat treatment technology Controlled optimum level for retained austenite 	<p>Microstructure</p> <p>Result P-extraction replica work using transmission electron microscopy (TEM)</p> <p>AISI 52100 SWR</p>						
<p>Basic performance</p> <p>Countermeasure (1) Wear resistance Fig. 1</p> <p>Countermeasure (2) Improved flaking life (inhibition of flaking) Fig. 2</p> <p>Countermeasure (3) Improved outer ring strength Fig. 3</p>	<p>Profile of wear on the outer ring raceway surface of spherical roller bearings</p> <p>AISI 52100 SWR</p> <p>Maximum wear depth: Approx. 17 μm Approx. 5 μm</p> <p>Wear resistance: approx. 3 times</p> <p>Evaluation of operating life by thrust-type life test</p> <p>Bearing life: approx. 5 times</p> <p>Evaluation of outer ring strength</p> <p>Core toughness: approx. 5 times</p>						
<p>Field endurance evaluation</p> <p>Evaluation in the application for slab continuous casting machines</p>	<p>Longer bearing life results in extended segment replacement cycles</p> <p>Bearing arrangement: Page 15-16</p> <table border="1"> <thead> <tr> <th>Bearings used in the segment</th> <th>Ratio of extended segment replacement cycles in R/A and P/R segments</th> </tr> </thead> <tbody> <tr> <td>Standard spherical roller bearings CASE 1 and 2</td> <td>Average segment replacement cycles: 1</td> </tr> <tr> <td>SWR Bearings CASE 1 and 2</td> <td>Average segment replacement cycles: 1.6 Maximum: 2</td> </tr> </tbody> </table> <p>SWR Bearings allow users, who have been forced to replace segments at frequent cycles due to the bearing life of standard spherical roller bearings, to attain maximum effect in reducing maintenance, by decreasing unexpected accidents and using rolls to the full extent of their operating life.</p>	Bearings used in the segment	Ratio of extended segment replacement cycles in R/A and P/R segments	Standard spherical roller bearings CASE 1 and 2	Average segment replacement cycles: 1	SWR Bearings CASE 1 and 2	Average segment replacement cycles: 1.6 Maximum: 2
Bearings used in the segment	Ratio of extended segment replacement cycles in R/A and P/R segments						
Standard spherical roller bearings CASE 1 and 2	Average segment replacement cycles: 1						
SWR Bearings CASE 1 and 2	Average segment replacement cycles: 1.6 Maximum: 2						

Development of tapered roller bearings with aligning rings and cylindrical roller bearings with aligning rings



<p>Development of new type bearings</p> <p>Comparison of PV value properties affecting the wear within the bearing</p> <p>Surface pressure (P), Sliding (V), Wear property parameter: PV (P×V)</p> <p>PV value between the outer ring raceway surface and roller raceway surface</p> <p>(1) Tapered roller bearing with aligning ring (2) Cylindrical roller bearing with aligning ring</p>	<p>PV value properties of 1) tapered roller bearing 2) cylindrical roller bearing</p> <p>PV=0</p>	<p>PV value properties of spherical roller bearing</p> <p>PV=0</p>						
<p>Wear evaluation</p> <p>Example of inspection of an abrasion level on the outer ring raceway surface</p> <ul style="list-style-type: none"> Tapered roller bearing with aligning ring (one-side): Fig. 1 Cylindrical roller bearing with aligning ring: Fig. 2 Standard spherical roller bearing: Fig. 3 	<p>Wear on the outer ring raceway surface was infinitesimal</p> <p>Amount of wear: 2 μm Amount of wear: 2 μm</p> <p>Fig. 1 Fig. 2</p>	<p>Outer ring raceway surface abrasion was significant: large uneven wear</p> <p>Amount of wear: 14 μm</p> <p>Fig. 3</p>						
<p>Field endurance evaluation</p> <p>Evaluation in the application for slab continuous casting machines</p>	<p>Service period: 21 months 12 months</p> <p>Longer bearing life results in extended segment replacement cycles</p> <p>Bearing arrangement: Page 15-16</p> <table border="1"> <thead> <tr> <th>Bearings used in the segment</th> <th>Ratio of extended segment replacement cycles in R/A and P/R segments</th> </tr> </thead> <tbody> <tr> <td>Standard spherical roller bearings CASE 1 and 2</td> <td>Average segment replacement cycles: 1</td> </tr> <tr> <td>Tapered roller bearings with aligning rings CASE 3</td> <td>Average segment replacement cycles: 1.6 Maximum: 2</td> </tr> </tbody> </table> <p>The usage of tapered roller bearings with aligning rings (for fixed end) and cylindrical roller bearings with aligning rings (for free end) reduced unexpected accidents and lowered maintenance costs to a minimum by using rolls to the full extent of their operating life. The used bearings, after the fatigue analysis by using X-ray, proved to have a residual life corresponding to 2-4 times the tested period.</p>	Bearings used in the segment	Ratio of extended segment replacement cycles in R/A and P/R segments	Standard spherical roller bearings CASE 1 and 2	Average segment replacement cycles: 1	Tapered roller bearings with aligning rings CASE 3	Average segment replacement cycles: 1.6 Maximum: 2	<p>Service period: 21 months 12 months</p>
Bearings used in the segment	Ratio of extended segment replacement cycles in R/A and P/R segments							
Standard spherical roller bearings CASE 1 and 2	Average segment replacement cycles: 1							
Tapered roller bearings with aligning rings CASE 3	Average segment replacement cycles: 1.6 Maximum: 2							



Estimated effect of maintenance cost reduction

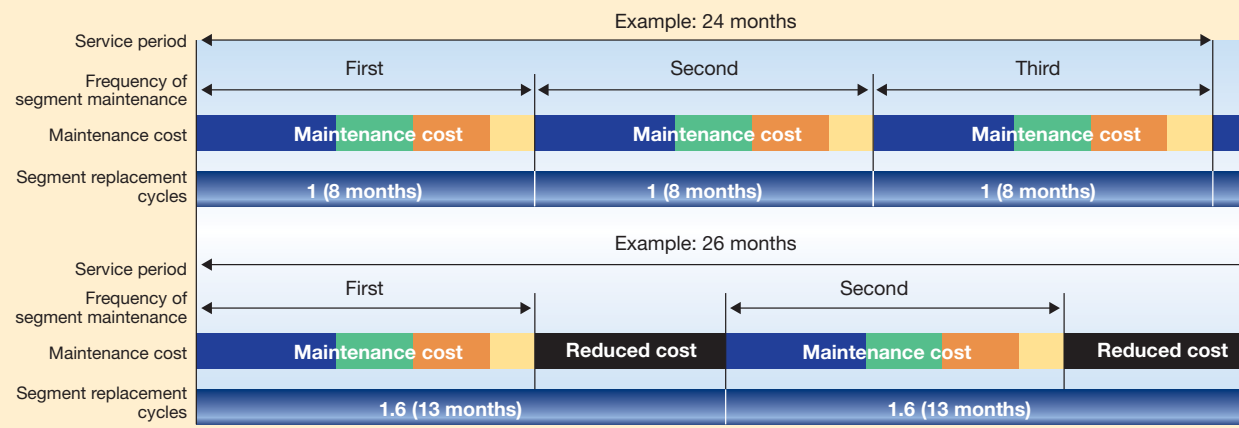

If SWR Bearings are used on 1-8 segments out of 15 segments of a 2-strand continuous casting machine, then segment life is extended on average 1.6 times. The estimated reduction effect is 20%-30% of total maintenance cost.



Benefits

- 1 Higher reliability and longer operating life prevent unexpected accidents
- 2 Bearing seal requires less cleaning of work environment and reduces grease consumption
- 3 Reduced maintenance costs

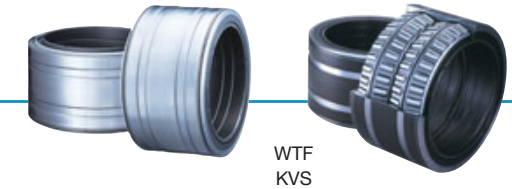

1. Operating conditions

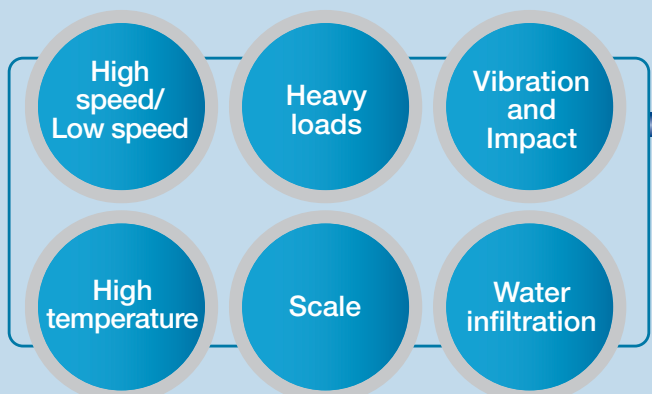

- Major target mills:
- Hot strip mills
 - Cold rolling mills
 - Skin pass mills
 - Temper rolling mills

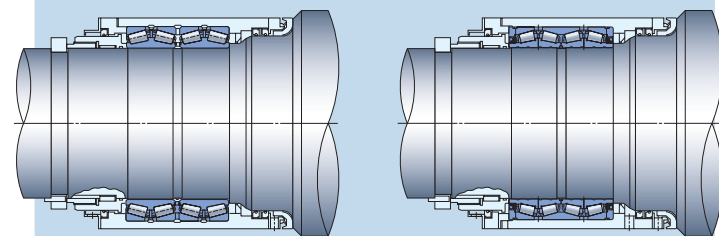
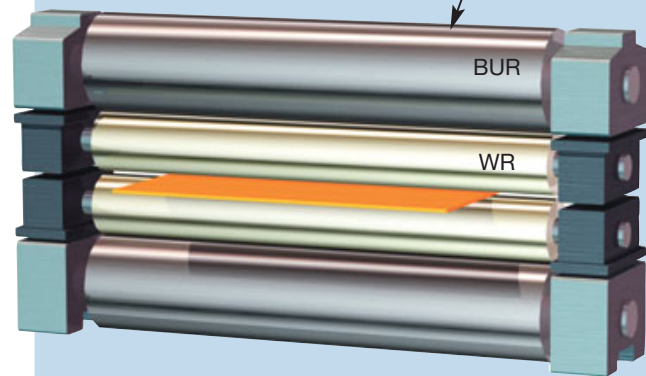
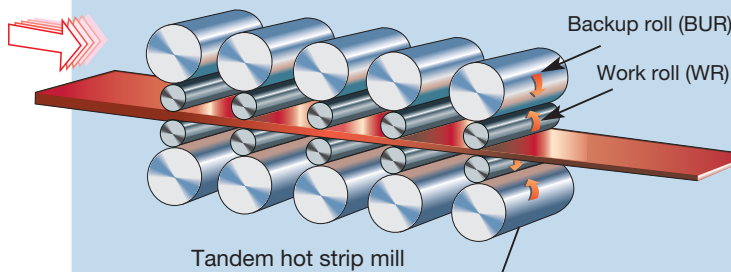

(1) Open type four-row tapered roller bearing

(2) Sealed four-row tapered roller bearing

2. Problems

Typical problems of work roll bearings

(1) Open type four-row tapered roller bearings

- (1) Large grease consumption and high maintenance costs
- (2) Premature failure due to poor lubrication

(2) Sealed four-row tapered roller bearings

Operating conditions, including loading, debris and water infiltration become severe

Flaking

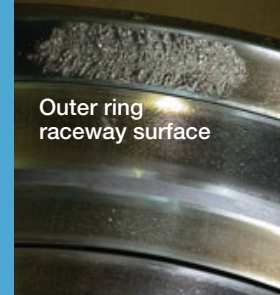

Outer ring raceway surface

Seizure

High bearing usage cost

Unexpected production line failure

3. Countermeasures

Material measures

- Identified flaking damage mechanism caused by water infiltration
- Developed countermeasures against severe conditions for cases where water and particle contamination are unavoidable

Features Water-TF® Bearings—WTF Series

- Adoption of super-clean steel with optimum alloy balance controls development and progress of cracks at early flaking stage caused by water infiltration
- Control of the retained austenite reduces concentration of stress resulting from dents caused by infiltration of debris

	Comparison of actual life extension in field test		
Conventional steel	1		
Material for Water TF Bearing		3	

Water-TF Bearings are a special purpose bearing series in the same design as the standard KVS types (see below).

User Benefit

Page 23–24

Material measures

- Developed countermeasures against harsh load conditions
- Improved sealing against water infiltration and foreign contamination

Features Extra-Capacity Sealed-Clean™ Four-Row Tapered Roller Bearings—KVS Series

- Higher load capacity: increased by 15%–35% compared to conventional sealed bearings
- Super-TF steel: resistant to foreign contamination, used as standard
- Controlled negative pressure during rolling to prevent water infiltration
- Improved sealing through usage of heat- and wear-resistant sealing materials
- Easier handling of seals

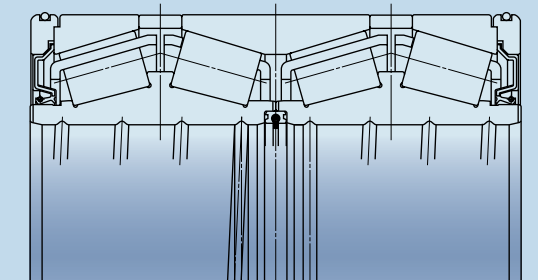

	Comparison of actual life extension in field test		
Conventional sealed bearing	1		
KVS Bearing		2	

User Benefit

Page 23–24

Bearing Series	WTF Series	KVS Series
Bearing No.	Page 33–34	Page 35–36

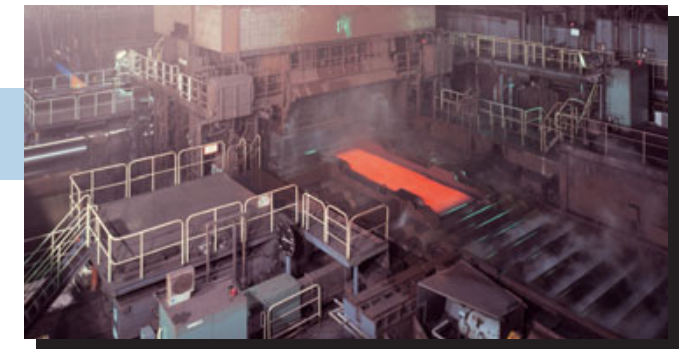

Benefits

- 1 Higher reliability and longer operating life prevent unexpected accidents
- 2 Reduced maintenance costs
- 3 Smoother rolling of bearings for backup rolls improves plate making precision

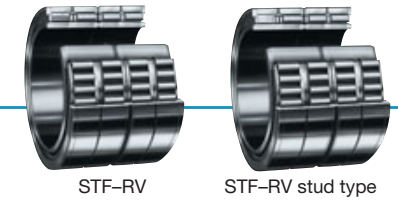

1. Operating conditions

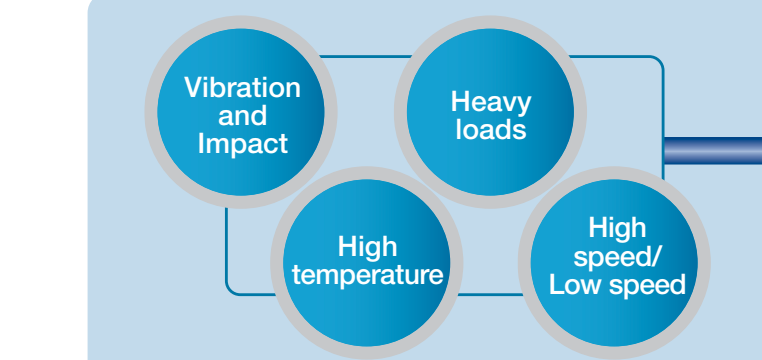

- Major target mills:
- Plate mills
 - Hot strip mills
 - Cold rolling mills
 - Skin pass mills
 - Temper rolling mills

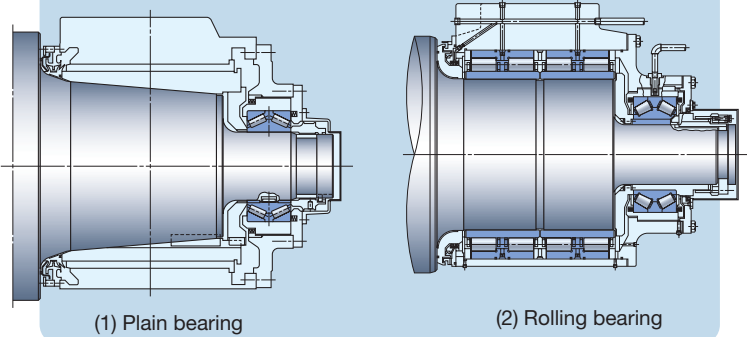
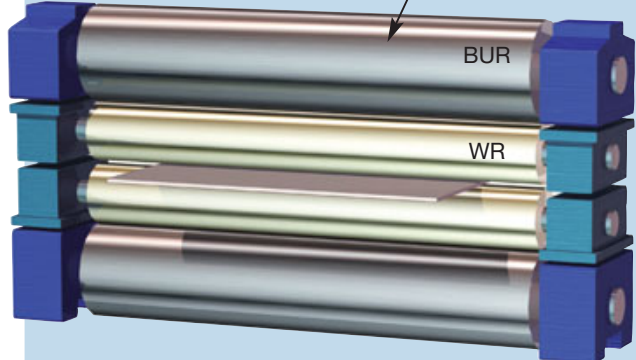
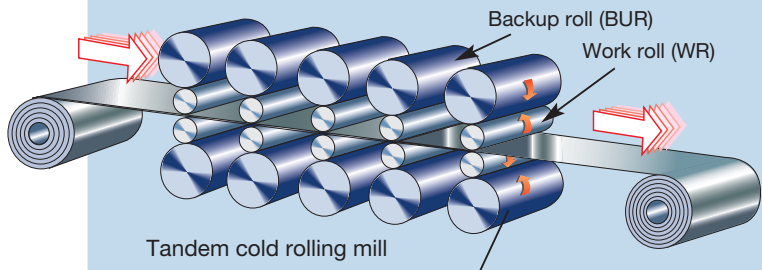

2. Problems

Typical problems of backup roll bearings

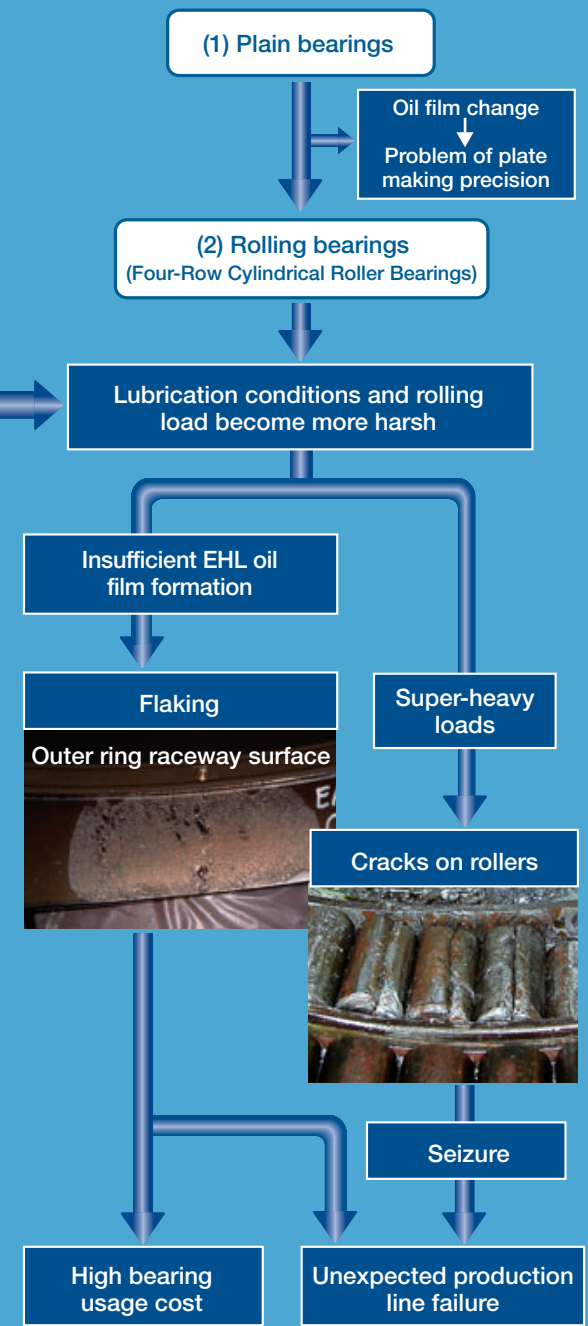

3. Countermeasures

- Material measures**
- Developed optimal bearing specifications for smoother rolling of backup rolls
 - Improved durability under harsh load conditions and insufficient oil film formation

Features Super-TF™ Four-Row Cylindrical Roller Bearings—STF-RV Series

- Longer life Super-TF steel, resulting in longer durability, even under boundary-lubrication with insufficient EHL oil film formation
- Higher load capacity by using pin type cage
- Higher rotational accuracy

	Comparison of actual life extension in the field test	
Conventional steel	1	
Super TF steel	2	

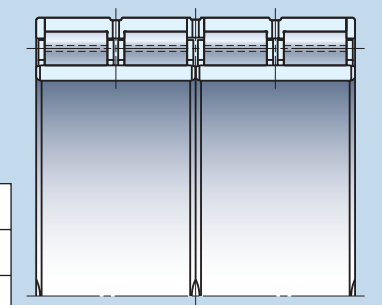

User Benefit Bearing usage cost reduced by 50%

- Design measures**
- Design measures against cracks on rollers under super-heavy loads conditions

Features Super-TF™ Four-Row Cylindrical Roller Bearings—STF-RV stud-type

Target: Bearings for backup rolls of plate mills

- Adoption of solid type rollers associated with the development of a stud-type cage
- Higher load capacity
- Adoption of long-life Super-TF steel
- Higher rotational accuracy

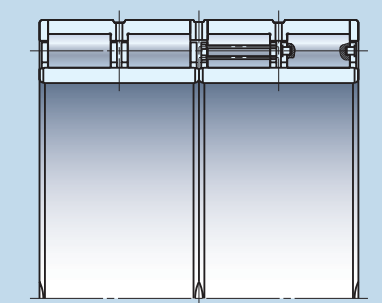

User Benefit Elimination of unexpected accidents caused by cracks on rollers

Bearing Series	STF-RV Series	STF-RV stud type
Bearing No.		

Contribution to Enhancement of Reliability and Reduction of Maintenance Costs for Rolling Mills

Identification of the failure mechanism

Failure mechanism of the four-row tapered roller bearings for work rolls for rolling mills

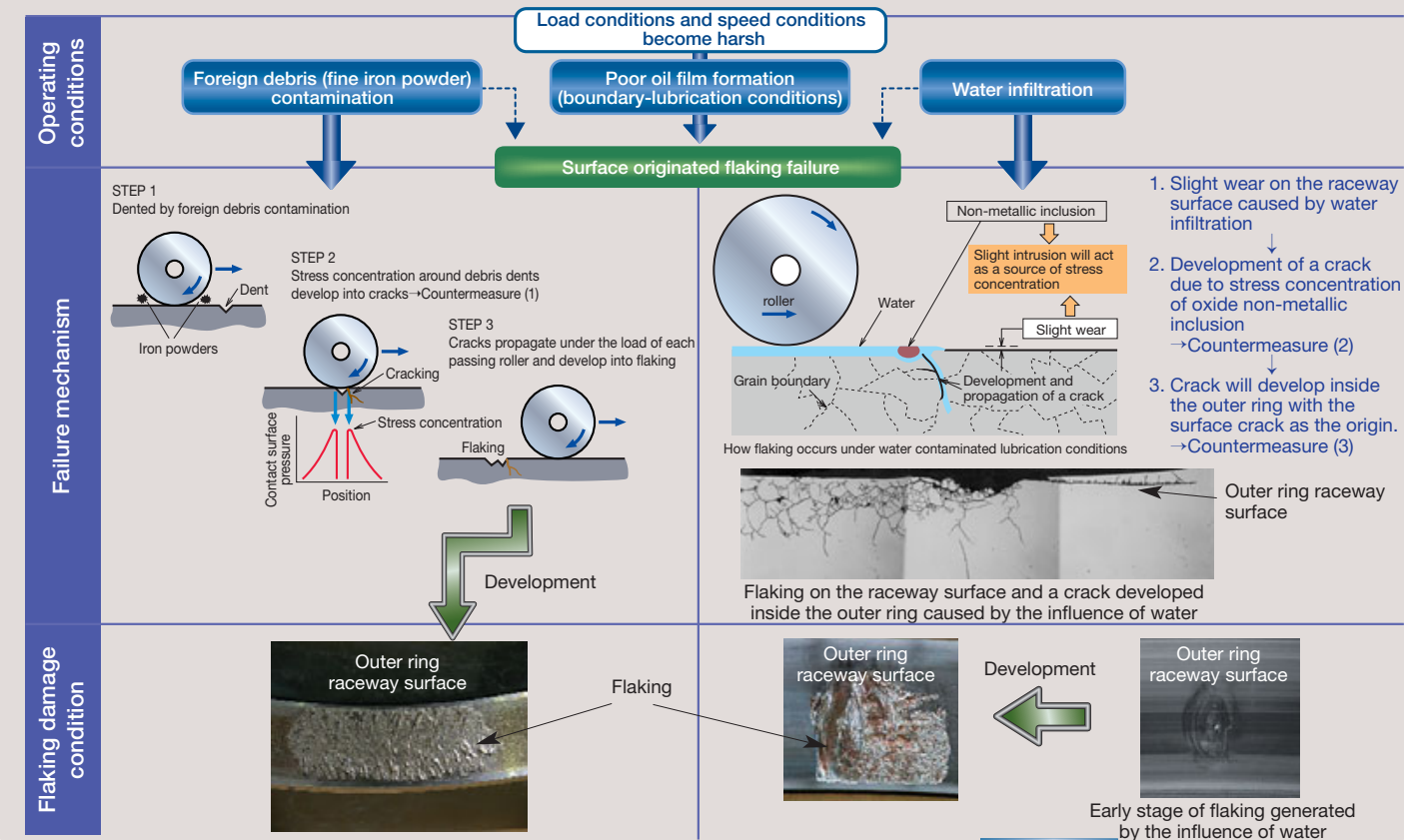

Design measures

Development of Extra-Capacity Sealed-Clean™ Four-Row Tapered Roller Bearings (KVS Series)

Design development: High-load capacity design (New internal structure specifications, combined with a new type of seal, increase bearing capacity (patent pending).); New seal and holder (The new seal and its holder make handling easier and minimize seal damage (patent pending).); New bore seal (The new bore seal prevents negative pressure that causes water entry and provides for easier mounting and dismounting (patents pending).)

KVS Series	
Basic load rating, C_r	15-35% increase
Estimated life, L_{10}	1.6 to 2.7 times of estimated life extension
Control of negative pressure inside the bearing	Negative pressure and water infiltration were reduced to less than 1/3
Performance of the bearing seal	

Please refer to CAT. No. E1255 for details.

Field durability performance: Evaluation result in an actual cold rolling mill (evaluation result in a Water-TF and KVS design). Target equipment: tandem cold rolling mills (4-high). Segment example: work rolls. Bearing type: sealed four-row tapered roller bearings (Fig. 1). Bearing No.: WTF343KVS4551.

Average life ratios of bearings for work rolls:

Conventional type sealed bearings	1
Water-TF Bearings	3

Cumulative failure probability graph: Shows that WTF steel has a significantly lower cumulative failure probability compared to conventional steel over time.

Water-TF Bearings demonstrated on average a three times longer life span for users who previously had been faced with bearings with short life spans due to water infiltration. Please refer to CAT. No. E1251 for detailed data.

Development of Super-TF™ Bearing and Water-TF® Bearing

Countermeasures: Countermeasure (1): Control of the retained austenite. Countermeasure (2): Super cleaning (special dissolution). Countermeasure (3): Chemical component design.

Super-TF Bearing: Application to bearings for backup rolls.

Water-TF Bearing: Application to bearings for work rolls.

Life test results:

Life of Super-TF Bearings under lubrication with foreign contamination and under boundary-lubrication	
1. Life test result under foreign contamination (tapered roller bearings)	
Catalog life	1
General carburized steel	0.2
Super-TF	2
2. Life test result under boundary-lubrication ($\Delta=0.3$) (ball-rod rolling contact fatigue test)	
General carburized steel	1
Super-TF	5.5

Please refer to CAT. No. E1203 for detailed data.

Water-TF Bearing Life Test: Life test result under lubrication contaminated by water and debris (tapered roller bearings). Bearing life: approx. 3 times.

Please refer to CAT. No. E1251 for detailed data.

User Benefit

Estimated effect of maintenance cost reduction

Bearing specifications	Maintenance cost		
	(1) Grease	(2) Bearing usage cost and seal repair cost	(3) Maintenance work cost for bearings
Open type bearings (without seal) Maintenance cycle: 3 months	3 buckets of grease	12 bearings	6 workers
Conventional sealed bearings Maintenance cycle: 6 months	1 bucket of grease	12 bearings	6 workers
Water-TF Bearings Maintenance cycle: 6 months	1 bucket of grease (90% reduction)	6 bearings (50% reduction)	3 workers (50% reduction)

Overall cost benefit in a five-stand cold rolling mill (four-high rolling) using Water-TF Bearings is roughly 30% to 35% compared to open-type bearings and maintenance cost benefit is roughly 25% to 30% if compared to conventional sealed bearings. Cost benefit is the sum of costs related to grease, bearing usage, seal repair, and maintenance costs ((1)+(2)+(3)).

Dimensions of Bearings for Sintering Equipment

Sealed-Clean Bearings for Pallet Wheels—AR Series

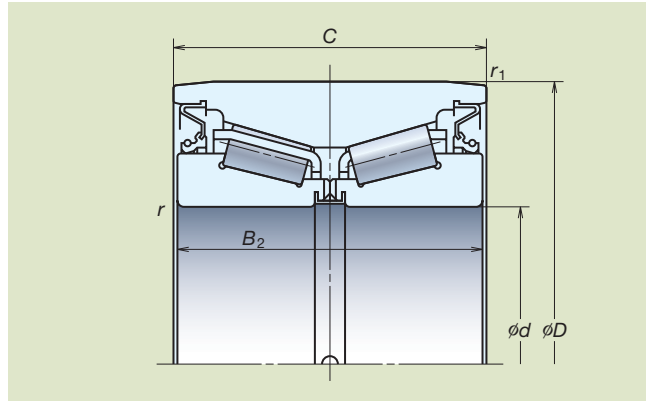

Bearing Numbers	Boundary Dimensions (mm)						Basic Load Ratings (kN)	
	d	D	B_2	C	r (min)	r_1 (min)	C_r	C_{Or}
AR80-24	80	150	67	67	2.5	1	269	390
AR90-25	90	160	74	74	2.5	0.5	240	435
AR90-26	90	160	80	80	2.5	0.5	240	435
AR90-27	90	160	78	78	2.5	0.5	240	435
AR100-29	100	180	98	100	2.5	1	350	675
AR100-30	100	180	100	100	2.5	1	350	675
AR100-38	100	180	100	100	3	0.5	525	835
AR100-40	100	180	98	100	3	0.5	525	835
AR110-28	110	180	86	86	3	0.5	330	660
AR110-29	110	200	92	100	2.5	1	415	805
AR110-39	110	200	100	100	3	1	570	950

Remarks: Other bearings are available. Please contact NSK for additional information.

Sealed-Clean Bearings for Inboard Rollers—2J Series

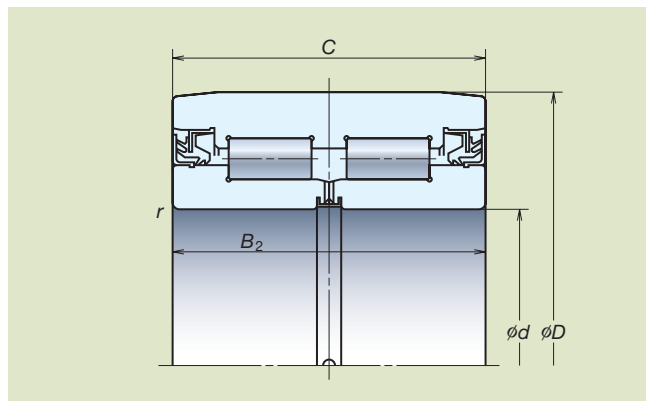

Bearing Numbers	Boundary Dimensions (mm)					Basic Load Ratings (kN)	
	d	D	B_2	C	r (min)	C_r	C_{Or}
2J100-2	100	200	120	119	2.1	315	910
2J120-9A	120	210	120	120	2.5	610	1 080
2J120-14	120	210	132	132	2.1	530	1 320
2J140-2	140	250	130	130	4	770	1 420
2J160Z-1	160.11	250	130	130	2.5	670	1 540
2J160Z-5	160.11	250	155	150	2.1	610	2 050

Remarks: Other bearings are available. Please contact NSK for additional information.

Dimensions of Bearings for BOFs and Converters

Ultra-Large Split Bearings for BOFs and Converter Trunnions

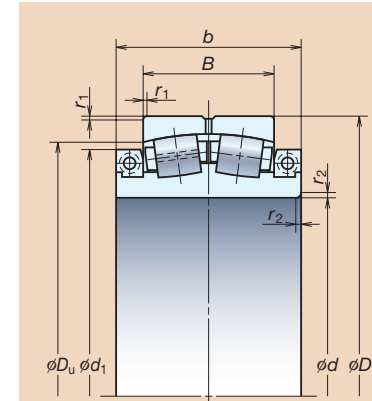

Fig. 1

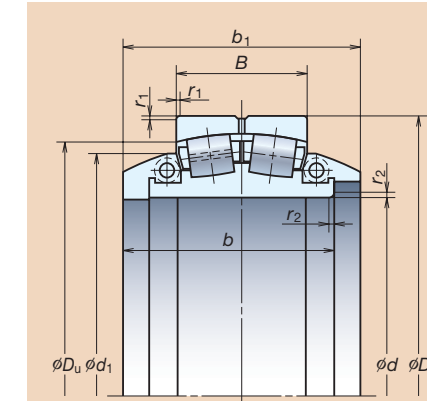

Fig. 2 Clamp ring with tangential seal surface



Bearing Numbers	Boundary Dimensions (mm)										Basic Load Ratings (kN)		Fig.
	d	D	B	b	b_1	d_1	D_u	r_1 (min)	r_2 (min)	C_r	C_{Or}		
750SLPT1051	750	1 000	250	355	—	905	914.4	6	7.5	6 800	18 300	1	
SL850-7	850	1 120	272	385	—	1 015	1 025	6	6	8 000	21 600	1	
900SLPT1251	900	1 250	285	410	—	1 100	1 142	7.5	19	9 850	24 200	1	
950SLPT1451	950	1 400	300	520	600	1 182	1 265	7.5	28	12 300	27 900	2	
SL1120-3	1 120	1 580	320	632.5	697.5	1 400	1 445	9.5	30	13 200	32 000	2	
1200SLPT1751	1 200	1 700	410	780	780	1 470	1 536	9.5	31	17 300	43 500	2	
1200SLPT1752	1 200	1 700	410	660	730	1 470	1 536	9.5	19	17 300	43 500	2	
1320SLPT1851	1 320	1 850	530	815	814	1 600	1 670	12	31	22 500	63 500	2	
1400SLPT1951	1 400	1 900	530	880	880	1 680	1 710	12	31	22 800	65 000	2	
1400SLPT1953	1 400	1 900	530	810	860	1 680	1 710	12	31	22 800	65 000	2	

Remarks: 1. The shapes of bearings marked * are not exactly the same as shown in Fig. 2.
2. Other bearings are available. Please contact NSK for additional information.

Dimensions of Bearings for Continuous Casting Machines

SWR™ Bearings (Spherical Roller Bearings) – SWR Series

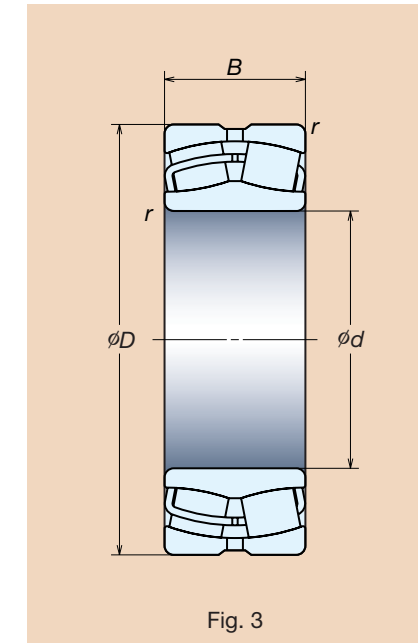
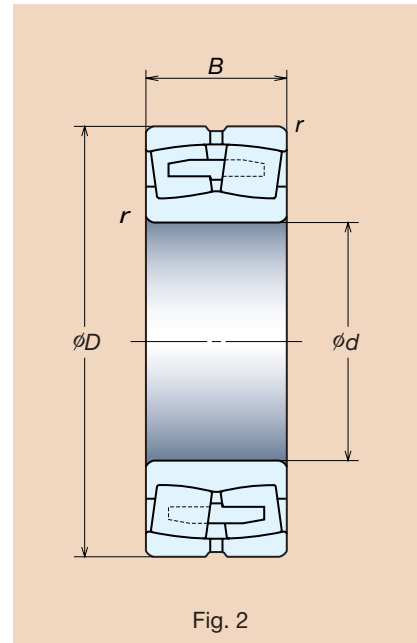
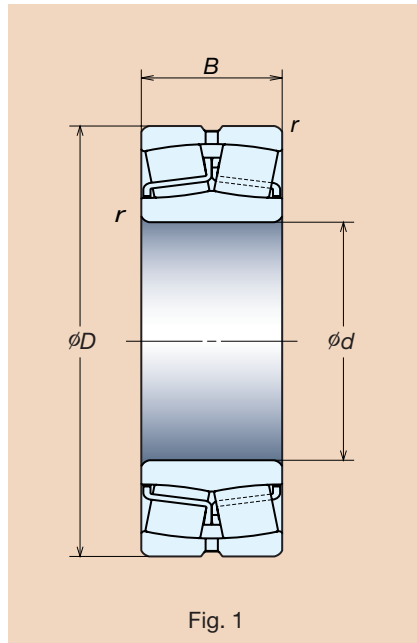

Bearing Numbers	Boundary Dimensions (mm)				Basic Load Ratings (kN)		Fig.
	d	D	B	r (min)	C_r	C_{or}	
22208SWREAg2E4	40	80	23	1.1	113	99.5	1
22210SWREAg2E4	50	90	23	1.1	124	119	1
23012SWRCg2E4	60	95	26	1.1	98.5	141	3
22212SWREAg2E4		110	28	1.5	178	174	1
22214SWREAg2E4	70	125	31	1.5	225	232	1
22216SWREAg2E4	80	140	33	2	264	275	1
22218SWREAg2E4	90	160	40	2	360	395	1
23020SWRCDg2E4	100	150	37	1.5	212	335	3
24020SWRCg2E4		150	50	1.5	276	470	3
24120SWRCAg2ME4		165	65	2	345	535	2
22220SWREAg2E4	110	180	46	2.1	455	490	1
23022SWRCDg2E4		170	45	2	293	465	3
24022SWRCg2E4		170	60	2	380	645	3
24122SWRCg2E4		180	69	2	460	750	3
22222SWREAg2E4	120	200	53	2.1	605	645	1
23024SWRCDg2E4		180	46	2	315	525	3
24024SWRCg2E4		180	60	2	395	705	3
24124SWRCg2E4		200	80	2	575	950	3
22224SWREAg2E4	130	215	58	2.1	685	765	1
23026SWRCDg2E4		200	52	2	400	655	3
24026SWRCg2E4		200	69	2	495	865	3
24126SWRCg2E4		210	80	2	590	1 010	3
22226SWREAg2E4	140	230	64	3	820	940	1
23028SWRCDg2E4		210	53	2	420	715	3
24028SWRCg2E4		210	69	2	525	945	3
24128SWRCg2E4		225	85	2.1	670	1 160	3
22228SWRCDg2E4		250	68	3	645	930	3

Bearing Numbers	Boundary Dimensions (mm)				Basic Load Ratings (kN)		Fig.
	d	D	B	r (min)	C_r	C_{or}	
23030SWRCDg2E4	150	225	56	2.1	470	815	3
24030SWRCg2E4		225	75	2.1	590	1 090	3
24130SWRCg2E4		250	100	2.1	890	1 530	3
22230SWRCDg2E4		270	73	3	765	1 120	3
23032SWRCDg2E4	160	240	60	2.1	540	955	3
24032SWRCg2E4		240	80	2.1	680	1 260	3
24132SWRCg2E4		270	109	2.1	1 040	1 760	3
22232SWRCDg2E4	170	290	80	3	910	1 320	3
23034SWRCDg2E4		260	67	2.1	640	1 090	3
24034SWRCg2E4		260	90	2.1	825	1 520	3
24134SWRCg2E4		280	109	2.1	1 080	1 860	3
22234SWRCDg2E4	180	310	86	4	990	1 500	3
23036SWRCDg2E4		280	74	2.1	750	1 270	3
24036SWRCg2E4		280	100	2.1	965	1 750	3
24136SWRCg2E4		300	118	3	1 190	2 040	3
22236SWRCDg2E4	190	320	86	4	1 020	1 540	3
23038SWRCAg2ME4		290	75	2.1	775	1 350	2
24038SWRCg2E4		290	100	2.1	975	1 840	3
24138SWRCg2E4		320	128	3	1 370	2 330	3
22238SWRCAg2ME4	200	340	92	4	1 140	1 730	2
23040SWRCAg2ME4		310	82	2.1	940	1 700	2
24040SWRCg2E4		310	109	2.1	1 140	2 120	3
24140SWRCg2E4		340	140	3	1 570	2 670	3
22240SWRCAg2ME4	220	360	98	4	1 300	2 010	2
23044SWRCAg2ME4		340	90	3	1 090	1 980	2
24044SWRCg2E4		340	118	3	1 360	2 600	3
24144SWRCg2E4		370	150	4	1 800	3 200	3
22244SWRCAg2ME4		400	108	4	1 570	2 430	2

Remarks: Other bearings are available. Please contact NSK for additional information.

Dimensions of Bearings for Continuous Casting Machines

Cylindrical Roller Bearings with Aligning Rings (With cage) – RUB Series

Bearing Numbers	Boundary Dimensions (mm)				Basic Load Ratings (kN)	
	Free End	d	D	B	r (min)	C_r
110RUB41	110	180	69	2	271	490
120RUB40	120	180	60	2	247	495
120RUB41		200	80	2	370	680
120RUB32	130	215	76	2.1	435	735
130RUB41		210	80	2	380	715
130RUB32	140	230	80	3	490	825
140RUB40		210	69	2	330	670
140RUB41	150	225	85	2.1	435	830
150RUB40		225	75	2.1	375	755
150RUB41	160	250	100	2.1	540	1 040
150RUB32		270	96	3	690	1 210
160RUB41	170	270	109	2.1	690	1 260
160RUB32		290	104	3	795	1 370
170RUB41	180	280	109	2.1	710	1 330
170RUB32		310	110	4	915	1 590
180RUB40	190	280	100	2.1	635	1 300
180RUB41		300	118	3	755	1 460
190RUB40	200	290	100	2.1	650	1 360
190RUB32		340	120	4	1 050	1 870
200RUB40	200	310	109	2.1	770	1 540
200RUB41		340	140	3	1 080	2 200

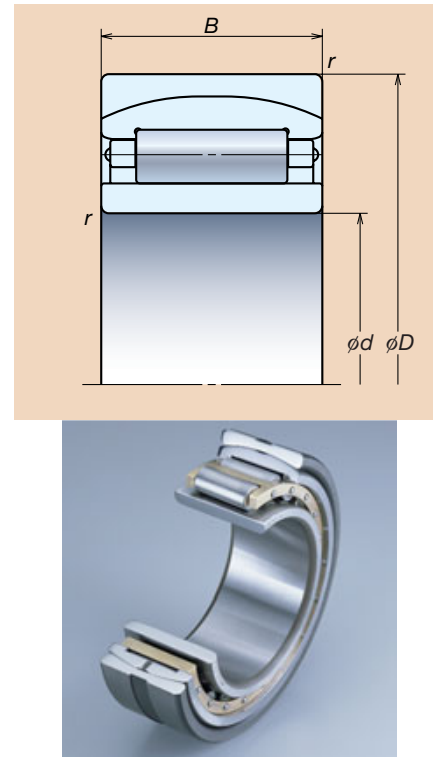

Remarks: Other bearings are available. Please contact NSK for additional information.

Cylindrical Roller Bearings with Aligning Rings (Full-complement) – RUB Series

Bearing Numbers	Boundary Dimensions (mm)				Basic Load Ratings (kN)	
	Free End	d	D	B	r (min)	C_r
110RUB41APV	110	180	69	2	375	805
110RUB32APV		200	69.8	2.1	440	805
120RUB40APV	120	180	60	2	305	715
120RUB41APV		200	80	2	450	985
120RUB32APV	130	215	76	2.1	510	990
130RUB40APV		200	69	2	405	935
130RUB41APV	140	210	80	2	480	1 050
130RUB32APV		230	80	3	585	1 090
140RUB40APV	150	210	69	2	420	990
140RUB41APV		225	85	2.1	545	1 230
140RUB32APV	160	250	88	3	715	1 390
150RUB40APV		225	75	2.1	435	1 070
150RUB41APV	170	250	100	2.1	710	1 620
150RUB32APV		270	96	3	815	1 640
160RUB40APV	180	240	80	2.1	490	1 200
160RUB41APV		270	109	2.1	855	1 830
160RUB32APV	190	290	104	3	960	1 890
170RUB40APV		260	90	2.1	640	1 520
170RUB41APV	200	280	109	2.1	875	1 900
170RUB32APV		310	110	4	1 060	2 090
180RUB40APV	180	280	100	2.1	785	1 870
180RUB41APV		300	118	3	940	2 120
180RUB32APV	190	320	112	4	1 090	2 190
190RUB40APV		290	100	2.1	810	1 980
190RUB41APV	200	320	128	3	1 120	2 480
190RUB32APV		340	120	4	1 210	2 430
200RUB40APV	200	310	109	2.4	960	2 250
200RUB41APV		340	140	3	1 300	2 930
200RUB32APV	360	128	4	1 320	2 760	

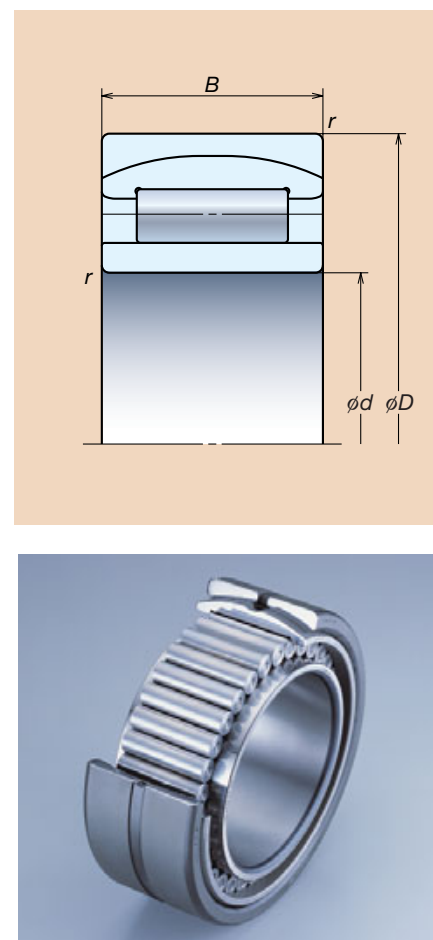

Remarks: Other bearings are available. Please contact NSK for additional information.

Tapered Roller Bearings with Aligning Rings – AR Series

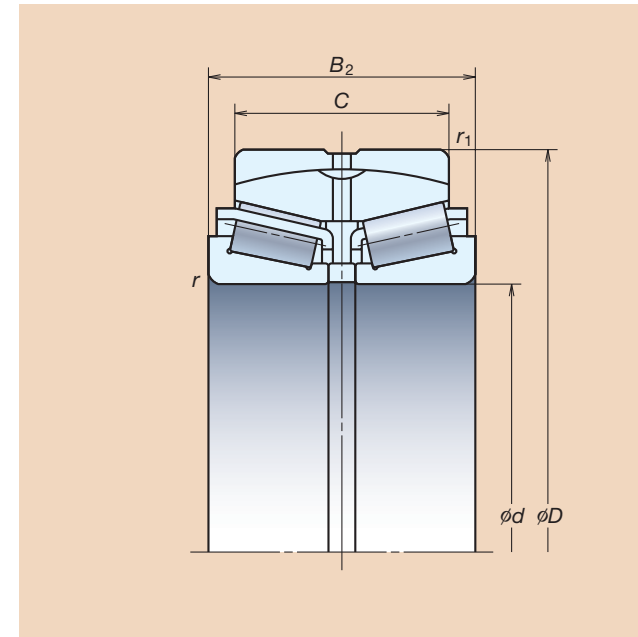

Bearing Numbers	Boundary Dimensions (mm)						Basic Load Ratings (kN)	
	Fixed End	d	D	B_2	C	r (min)	r_1 (min)	C_r
AR80-31	80	140	46	33	2	2	144	205
AR90-34	90	190	64	58	3	3	300	430
AR100-42	100	180	60	46	2.1	2.1	256	390
AR110-46	110	170	45	38	2	2.5	171	310
AR120-30	120	180	60	48	2	2.5	256	525
AR130-31	130	200	69	55	2	2.5	320	650
AR130-37		230	95	80	3	3	530	1 010
AR140-24	140	210	69	55	2.5	2.5	340	690
AR140-27		225	85	70	2.1	2.1	445	905
AR140-28		225	68	54	2.5	2.5	385	620
AR140-29		210	53	43	2	2.5	252	460
AR150-1	150	225	75	60	2.5	2.5	395	845
AR160-11	160	240	80	65	2.1	2.1	455	935
AR180-1	180	280	100	80	3	2.5	665	1 430
AR200-18	200	340	112	92	3	3	895	1 630

Remarks: Other bearings are available. Please contact NSK for additional information.

Dimensions of Bearings for Continuous Casting Machines

Split Cylindrical Roller Bearings (for segmented rolls) – RNPH Series

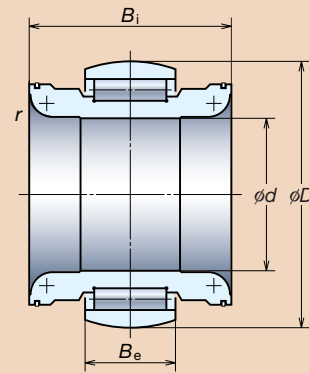

Fig. 1

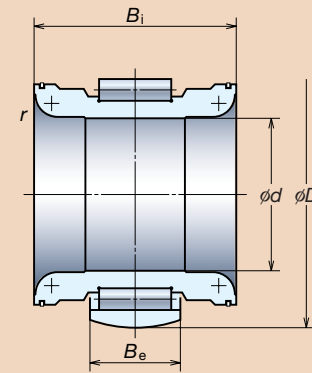
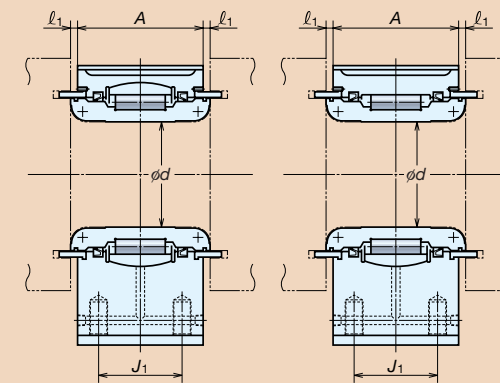
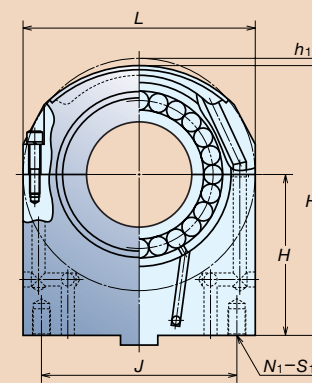

Fig. 2

Bearing Numbers	Boundary Dimensions (mm)					Basic Load Ratings (kN)		Roll Diameter (mm)	Fig.
	d	D	B_i	B_e	r	C_r	C_{0r}		
100RNPH1801	100	185	169	74	15	475	950	225	2
110RNPH1801	110	180	137	49	15	272	570	230	2
110RNPH1803	110	185	154	76	20	450	1 070	230	2
110RNPH2001	110	200	179	80	20	535	1 090	250	2
115RNPH2001	115	205	202	98	15	625	1 460	240	2
120RNPH1901	120	195	157	66	20	410	950	250	2
120RNPH2001	120	205	179	80	20	560	1 220	255	2
130RNP2001	130	205	139	60	20	455	1 030	270	1
130RNP2101	130	215	174	75	20	540	1 190	280	1
130RNPH2105	130	215	143	60	20	460	975	250	2
130RNPH2107	130	215	174	75	20	550	1 230	250	2
130RNPH2201	130	225	189	90	20	670	1 460	280	2
130RNPH2202	130	220	186	79	20	555	1 370	280	2
135RNPH2101	135	215	183	84	20	570	1 350	250	2
135RNPH2102	135	210	183	84	20	515	1 350	250	2
140RNPH2102	140	215	162	60	20	415	950	270	2
140RNPH2103	140	215	189	74	2.5	490	1 170	265	2
140RNPH2302	140	235	194	84	20	665	1 530	285	2
140RNP2401	140	245	184	85	20	710	1 510	310	1
145RNPH2201	145	225	179	76	20	560	1 340	280	2
145RNPH2303	145	232	196	84	20	630	1 440	280	2
145RNPH2401	145	240	208	89	20	765	1 780	295	2
150RNPH2303	150	230	199	78	2.5	555	1 340	280	2
150RNPH2401	150	245	159	80	20	680	1 550	280	2
150RNPH2403	150	240	195	84	18	690	1 630	290	2
150RNPH2503	150	250	169	70	20	640	1 500	300	2
150RNPH2505	150	250	208	89	20	780	1 840	295	2
150RNPH2601	150	265	187	98	20	900	1 950	320	2
150RNPH2702	150	275	199	100	20	945	1 970	330	2
155RNPH2401	155	245	199	88	20	740	1 720	300	2
160RNPH2502	160	255	199	90	20	735	1 730	310	2
160RNPH2504	160	255	189	86	20	745	1 780	305	2
160RNPH2601	160	265	200	82	20	745	1 700	320	2
160RNPH2703	160	275	214	100	25	945	2 190	325	2
170RNPH2601	170	265	214	100	20	880	2 050	330	2
180RNPH2901	180	290	214	85	20	880	2 050	335	2

Remarks: Other bearings are available. Please contact NSK for additional information.

Plummer Units for Split Cylindrical Roller Bearings – PCR Series



Bearing Numbers	Shaft Diameter (mm) d	Boundary Dimensions (mm)									
		L	A	H	h_1	H_2	l_1	J	J_1	N_1	S_1
100PCR2201	100	235	152	132	10	234.5	9	165	100	4	M20
110PCR2301	110	230	120	160	10	265	9.5	140	—	2	M30
110PCR2303	110	230	135	180	10	285	10	170	—	2	M30
110PCR2502	110	250	156	150	11.5	263.5	12	—	—	1	M36
115PCR2401	115	245	183	190	10	300	10	150	—	2	M24
120PCR2501	120	250	142	165	11.5	278.5	9	190	90	4	M24
120PCR2502	120	255	162	230	10	347.5	9	205	100	4	M24
130PCR2701	130	265	118	190	11.5	313.5	11	195	65	4	M30
130PCR2801	130	280	156	160	10	290	9.5	200	100	4	M24
130PCR2705	130	270	132	197	9	313	6	220	93	4	3/4-10UNC
130PCR2604	130	265	175	145	10	260	7.5	210	120	4	M16
130PCR2802	130	280	172	180	11.5	308.5	9	220	110	4	M30
130PCR2603	130	265	171	175	12.5	295	8	230	90	4	M20
135PCR2701	135	270	160	160	10	275	12	180	130	4	M20
135PCR2502	135	250	160	160	10	275	12	150	130	4	M20
140PCR2701	140	270	145	180	10	305	9.5	170	—	2	M30
140PCR2601	140	265	174	175	7.5	300	8	230	130	4	M20
140PCR2804	140	285	179	175	12.5	305	8	250	97.5	4	M20
140PCR3101	140	310	166	175	10	320	9.5	220	110	4	M24
145PCR2801	145	280	162	250	10	380	9	220	100	4	M30
145PCR2804	145	280	183	260	10	390	7	220	123	4	M30
145PCR2901	145	295	195	270	10	407.5	7	230	130	4	M30
150PCR2801	150	280	184	175	10	305	8	230	140	4	M20
150PCR280	150	330	144	310	10	440	8	350	260	4	φ33
150PCR3004	150	305	180	205.5	14.5	336	8	230	120	4	M24
150PCR3003	150	300	150	180	10	320	10	195	90	4	M30
150PCR2901	150	295	193	310	10	447.5	8	215	126	4	M30
150PCR3203	150	320	168	220	15	365	10	240	90	4	M36
150PCR3301	150	330	182	220	11.5	373.5	9	260	110	4	M36
155PCR3001	155	300	182	260	10	400	9	240	110	4	M30
160PCR3101	160	310	178	185	16.5	323.5	11	150	—	2	M30
160PCR3002	160	305	174	217	12.5	357	8	255	135	4	3/4-10UNC
160PCR3302	160	330	185	225	20	365	8	250	130	4	M24
160PCR3401	160	340	199	200	15.5	347	8	290	130	4	M20
170PCR3301	170	320	194	290.5	10	445.5	10.5	260	340	4	φ26
180PCR3301	180	335	150	217.5	10	375	10	240	82	4	M30

Remarks: Other bearings are available. Please contact NSK for additional information.

Dimensions of Bearings for Rolling Mills

Water-TF® Bearings – WTF Series

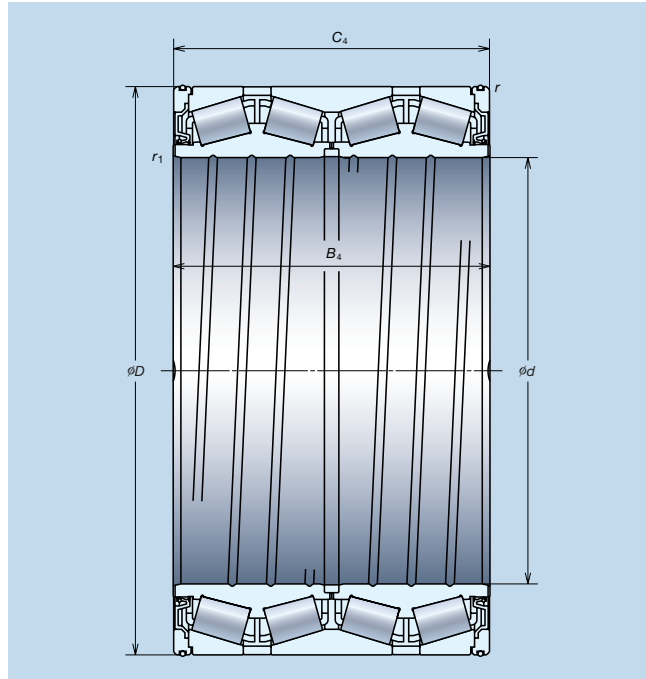

Dynamic Equivalent Load

$$P = XF_r + YF_a$$

$F_a / F_r \leq e$		$F_a / F_r > e$	
X	Y	X	Y
1	Y_3	0.67	Y_2

Static Equivalent Load

$$P_0 = F_r + Y_0 F_a$$

Where $Y_0 = Y_3$

The values of e , Y_2 , and Y_3 are given in the table.



Bearing Numbers	Boundary Dimensions (mm/inch)						Basic Load Ratings (kN)		Constant	Axial Load Factors		
	d	D	B_4	C_4	r (min)	r_1 (min)	C_r	C_{0r}		e	Y_2	Y_3
WTF170KVS2401Eg	170	240	175	175	2.5	2.5	1 020	2 010	0.32	3.2	2.1	
*WTF215KVS2851Eg	215.900 (8.5000)	288.925 (11.3750)	177.800 (7.0000)	177.800 (7.0000)	3.3	0.8	1 070	2 350	0.49	2.1	1.4	
*WTF216KVS3351Eg	216.103 (8.5080)	330.2 (13.0000)	263.525 (10.3750)	269.875 (10.6250)	3.3	1.5	2 290	4 550	0.46	2.2	1.5	
WTF220KVS3301Eg	220	330	260	260	3	4	2 330	4 800	0.40	2.5	1.7	
*WTF234KVS3251Eg	234.950 (9.2500)	327.025 (12.8750)	196.850 (7.7500)	196.850 (7.7500)	3.3	1.5	1 550	3 200	0.46	2.2	1.5	
*WTF244KVS3251Eg	244.475 (9.6250)	327.025 (12.8750)	193.680 (7.6250)	193.680 (7.6250)	3	1.5	1 370	3 050	0.40	2.5	1.7	
WTF245KVS3402Eg	245	345	310	310	3	2	2 700	6 650	0.40	2.5	1.7	
*WTF254KVS3552Eg	254.000 (10.0000)	358.775 (14.1250)	269.875 (10.6250)	269.875 (10.6250)	3.3	1.5	2 420	5 500	0.40	2.5	1.7	
WTF260KVS3601Eg	260	365	340	340	4	2.7	2 960	7 350	0.40	2.5	1.7	
WTF260KVS3651Eg	260	365	340	340	4	2.5	2 960	7 350	0.40	2.5	1.7	
*WTF260KVS4251Eg	260.350 (10.2500)	422.275 (16.6250)	314.325 (12.3750)	317.500 (12.5000)	3.3	6.4	3 600	7 050	0.33	3.0	2.0	
*WTF266KVS3551Eg	266.700 (10.5000)	355.600 (14.0000)	230.188 (9.0625)	228.600 (9.0000)	3.3	1.5	1 960	4 600	0.35	2.9	1.9	
*WTF276KVS3952Eg	276.225 (10.8750)	393.700 (15.5000)	269.875 (10.6251)	269.875 (10.6251)	3.3	1.5	2 720	6 100	0.45	2.2	1.5	
*WTF279KVS3952Eg	279.400 (11.0000)	393.700 (15.5000)	269.875 (10.6250)	269.875 (10.6250)	6.4	1.5	2 720	6 100	0.45	2.2	1.5	

Remarks: Other bearings are available. Please contact NSK for additional information.

Bearing Numbers	Boundary Dimensions (mm/inch)						Basic Load Ratings (kN)		Constant	Axial Load Factors		
	d	D	B_4	C_4	r (min)	r_1 (min)	C_r	C_{0r}		e	Y_2	Y_3
WTF279KVS3954Eg	279.4	393.7	320	320	6.4	1.5	3 100	7 350	0.40	2.5	1.7	
WTF290KVS4001Eg	290	400	346	346	4	3	3 250	8 400	0.40	2.5	1.7	
*WTF304KVS4351Eg	304.648 (11.9940)	438.048 (17.2460)	280.990 (11.6260)	279.400 (11.0000)	3.3	3.3	3 100	6 750	0.45	2.2	1.5	
*WTF304KVS4155Eg	304.800 (12.0000)	419.100 (16.5000)	269.875 (10.6250)	269.875 (10.6250)	6.4	1.5	2 850	6 550	0.33	3.0	2.0	
*WTF304KVS4152Eg	304.902 (12.0040)	412.648 (16.2460)	266.700 (10.5000)	266.700 (10.5000)	3.3	1.5	2 760	6 500	0.33	3.0	2.0	
WTF310KVS4301Eg	310	430	310	310	3	3	3 350	8 200	0.46	2.2	1.5	
WTF310KVS4302Eg	310	430	350	350	3	2.7	3 700	9 550	0.46	2.2	1.5	
*WTF317KVS4251Eg	317.500 (12.5000)	422.275 (16.6250)	269.875 (10.6250)	269.875 (10.6250)	3.3	1.5	2 740	6 750	0.34	3.0	2.0	
*WTF343KVS4551Eg	343.052 (13.5060)	457.098 (17.9960)	254.000 (10.0000)	254.000 (10.0000)	3.3	1.5	2 830	6 700	0.45	2.2	1.5	
*WTF355KVS4551Eg	355.600 (14.0000)	457.200 (18.0000)	252.412 (9.9375)	252.412 (9.9375)	3.3	1.5	2 650	6 750	0.32	3.2	2.1	
*WTF406KVS5451Eg	406.400 (16.0000)	546.100 (21.5000)	288.925 (11.3750)	288.925 (11.3750)	6.4	1.5	3 950	9 450	0.48	2.1	1.4	
WTF450KVS5901Eg	450	595	368	368	5	4	5 550	15 000	0.33	3.0	2.0	
*WTF457KVS5951Eg	457.200 (18.0000)	596.900 (23.5000)	276.225 (10.8750)	279.400 (11.0000)	3.3	1.5	4 000	9 850	0.47	2.2	1.4	
*WTF482KVS6151Eg	482.600 (19.0000)	615.950 (24.2500)	330.200 (13.0000)	330.200 (13.0000)	6.4	4.3	4 900	13 500	0.33	3.1	2.1	

Note: (*) Bearings marked * are inch designs.

Remarks: Water-TF Bearings are a special purpose bearing series in the same design as the standard Extra-Capacity Sealed-Clean Four-Row Tapered Roller Bearings.

Dimensions of Bearings for Rolling Mills

Extra-Capacity Sealed-Clean™ Four-Row Tapered Roller Bearings—KVS Series

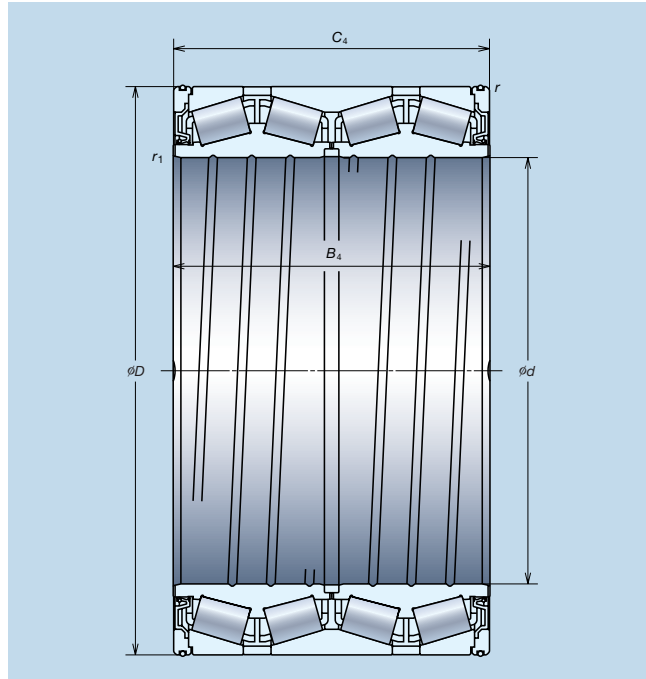

Dynamic Equivalent Load

$$P = XF_r + YF_a$$

$F_a / F_r \leq e$		$F_a / F_r > e$	
X	Y	X	Y
1	Y_3	0.67	Y_2

Static Equivalent Load

$$P_0 = F_r + Y_0 F_a$$

Where $Y_0 = Y_3$

The values of e , Y_2 , and Y_3 are given in the table.



Bearing Numbers	Boundary Dimensions (mm/inch)						Basic Load Ratings (kN)		Constant	Axial Load Factors	
	d	D	B_4	C_4	r (min)	r_1 (min)	C_r	C_{0r}		e	Y_2
STF170KVS2401Eg	170	240	175	175	2.5	2.5	1 020	2 010	0.32	3.2	2.1
*STF215KVS2851Eg	215.900 (8.5000)	288.925 (11.3750)	177.800 (7.0000)	177.800 (7.0000)	3.3	0.8	1 070	2 350	0.49	2.1	1.4
*STF216KVS3351Eg	216.103 (8.5080)	330.2 (13.0000)	263.525 (10.3750)	269.875 (10.6250)	3.3	1.5	2 290	4 550	0.46	2.2	1.5
STF220KVS3301Eg	220	330	260	260	3	4	2 330	4 800	0.40	2.5	1.7
*STF234KVS3251Eg	234.950 (9.2500)	327.025 (12.8750)	196.850 (7.7500)	196.850 (7.7500)	3.3	1.5	1 550	3 200	0.46	2.2	1.5
*STF244KVS3251Eg	244.475 (9.6250)	327.025 (12.8750)	193.680 (7.6250)	193.680 (7.6250)	3	1.5	1 370	3 050	0.40	2.5	1.7
STF245KVS3402Eg	245	345	310	310	3	2	2 700	6 650	0.40	2.5	1.7
*STF254KVS3552Eg	254.000 (10.0000)	358.775 (14.1250)	269.875 (10.6250)	269.875 (10.6250)	3.3	1.5	2 420	5 500	0.40	2.5	1.7
STF260KVS3601Eg	260	365	340	340	4	2.7	2 960	7 350	0.40	2.5	1.7
STF260KVS3651Eg	260	365	340	340	4	2.5	2 960	7 350	0.40	2.5	1.7
*STF260KVS4251Eg	260.350 (10.2500)	422.275 (16.6250)	314.325 (12.3750)	317.500 (12.5000)	3.3	6.4	3 600	7 050	0.33	3.0	2.0
*STF266KVS3551Eg	266.700 (10.5000)	355.600 (14.0000)	230.188 (9.0625)	228.600 (9.0000)	3.3	1.5	1 960	4 600	0.35	2.9	1.9
*STF276KVS3952Eg	276.225 (10.8750)	393.700 (15.5000)	269.875 (10.6251)	269.875 (10.6251)	3.3	1.5	2 720	6 100	0.45	2.2	1.5
*STF279KVS3952Eg	279.400 (11.0000)	393.700 (15.5000)	269.875 (10.6250)	269.875 (10.6250)	6.4	1.5	2 720	6 100	0.45	2.2	1.5

Remarks: Other bearings are available. Please contact NSK for additional information.

Bearing Numbers	Boundary Dimensions (mm/inch)						Basic Load Ratings (kN)		Constant	Axial Load Factors	
	d	D	B_4	C_4	r (min)	r_1 (min)	C_r	C_{0r}		e	Y_2
STF279KVS3954Eg	279.4	393.7	320	320	6.4	1.5	3 100	7 350	0.40	2.5	1.7
STF290KVS4001Eg	290	400	346	346	4	3	3 250	8 400	0.40	2.5	1.7
*STF304KVS4351Eg	304.648 (11.9940)	438.048 (17.2460)	280.990 (11.6260)	279.400 (11.0000)	3.3	3.3	3 100	6 750	0.45	2.2	1.5
*STF304KVS4155Eg	304.800 (12.0000)	419.100 (16.5000)	269.875 (10.6250)	269.875 (10.6250)	6.4	1.5	2 850	6 550	0.33	3.0	2.0
*STF304KVS4152Eg	304.902 (12.0040)	412.648 (16.2460)	266.700 (10.5000)	266.700 (10.5000)	3.3	1.5	2 760	6 500	0.33	3.0	2.0
STF310KVS4301Eg	310	430	310	310	3	3	3 350	8 200	0.46	2.2	1.5
STF310KVS4302Eg	310	430	350	350	3	2.7	3 700	9 550	0.46	2.2	1.5
*STF317KVS4251Eg	317.500 (12.5000)	422.275 (16.6250)	269.875 (10.6250)	269.875 (10.6250)	3.3	1.5	2 740	6 750	0.34	3.0	2.0
*STF343KVS4551Eg	343.052 (13.5060)	457.098 (17.9960)	254.000 (10.0000)	254.000 (10.0000)	3.3	1.5	2 830	6 700	0.45	2.2	1.5
*STF355KVS4551Eg	355.600 (14.0000)	457.200 (18.0000)	252.412 (9.9375)	252.412 (9.9375)	3.3	1.5	2 650	6 750	0.32	3.2	2.1
*STF406KVS5451Eg	406.400 (16.0000)	546.100 (21.5000)	288.925 (11.3750)	288.925 (11.3750)	6.4	1.5	3 950	9 450	0.48	2.1	1.4
STF450KVS5901Eg	450	595	368	368	5	4	5 550	15 000	0.33	3.0	2.0
*STF457KVS5951Eg	457.200 (18.0000)	596.900 (23.5000)	276.225 (10.8750)	279.400 (11.0000)	3.3	1.5	4 000	9 850	0.47	2.2	1.4
*STF482KVS6151Eg	482.600 (19.0000)	615.950 (24.2500)	330.200 (13.0000)	330.200 (13.0000)	6.4	4.3	4 900	13 500	0.33	3.1	2.1

Remarks: 1. Extra-Capacity Sealed-Clean Four-Row Tapered Roller Bearings are made of NSK Super-TF material as the standard specification.

2. Bearings marked * are inch design and numerical values in parentheses under Boundary Dimensions are in inches.

Dimensions of Bearings for Rolling Mills

Super-TF™ Four-Row Cylindrical Roller Bearings—STF-RV Series (Fig.1)

Bearing Numbers	Boundary Dimensions (mm)					Basic Load Ratings (kN)	
	d	D	B	C_2	F_w	C_r	C_{0r}
STF380RV5414g	380	540	300	300	421	4 450	9 700
STF380RV5411g	380	540	400	400	422	6 000	14 400
STF400RV5611g	400	560	410	410	445	6 550	16 500
STF420RV6012g	420	600	440	440	465	7 300	17 200
STF430RV5911g	430	591	420	420	476	6 350	16 100
STF440RV6215g	440	620	450	450	487	8 100	19 700
STF460RV6513g	460	650	470	470	509	8 600	21 200
STF470RV6611g	470	660	470	470	519	8 450	20 800
STF480RV6814g	480	680	420	420	528	8 350	19 000
STF480RV6815g	480	680	500	500	532	9 400	23 500
STF500RV6713g	500	670	450	450	540	7 750	20 000
STF500RV7111g	500	710	480	480	558	8 500	21 200
STF500RV7214g	500	720	530	530	568	10 100	25 900
STF510RV6811g	510	680	500	500	560	8 950	25 700
STF520RV7311g	520	735	535	535	574.5	10 800	27 500
STF530RV7811g	530	780	570	570	601	11 800	29 200
STF550RV7413g	550	740	510	510	600	10 100	27 600
STF560RV8011g	560	800	600	600	620	12 400	31 500
STF560RV8211g	560	820	600	600	625	14 100	34 000
STF570RV8113g	570	815	594	594	628	13 200	32 000
STF600RV8212g	600	820	575	575	660	12 900	35 500
STF600RV8511g	600	850	600	600	664	14 600	37 500
STF600RV8711g	600	870	640	640	682	15 700	40 000
STF600RV8714g	600	870	640	640	669	15 700	40 000
STF628RV9211g	628	922	600	600	702	15 600	37 000
STF634RV9011g	634.5	901.87	674	674	705	17 000	44 500
STF650RV9212g	650	920	670	670	723	16 200	44 000
STF660RV9311g	660	930	660	660	728	17 000	44 000
STF690RV9611g	690	960	670	670	760	17 400	47 000
STF690RV9813g	690	980	750	750	766	19 200	53 000
STF700RV9313g	700	930	620	620	763	14 800	43 000
STF700RV9812g	700	980	700	700	766	18 800	49 000
STF725RV1012g	725	1 000	700	700	790	19 000	51 500
STF730RV1011g	730	1 030	750	750	809	20 700	56 500
STF750RV1013g	750	1 000	670	670	813	17 500	50 000
STF760RV1012g	760	1 030	750	750	828	20 800	60 000
STF761RV1012g	761.425	1 079.6	787.4	787.4	846	23 900	65 500
STF770RV1011g	770	1 075	770	770	847	23 100	63 500
STF800RV1013g	800	1 080	700	700	878	19 100	56 000
STF800RV1012g	800	1 080	750	750	880	19 300	57 000
STF820RV1119g	820	1 100	745	720	892	20 100	59 000
STF820RV11112g	820	1 130	650	650	891	20 300	53 000
STF820RV11110g	820	1 130	800	800	903	22 900	66 500
STF840RV1111g	840	1 160	840	840	920	24 900	71 500
STF850RV1115g	850	1 150	840	840	928	25 600	77 500
STF850RV1111g	850	1 180	850	850	940	24 700	72 500
STF900RV1216g	900	1 220	810	800	981	25 900	74 500
STF900RV1212g	900	1 220	840	840	989	26 800	80 000
STF900RV1217g	900	1 280	930	930	1 000	33 000	93 000
STF950RV1314g	950	1 330	950	950	1 053	33 500	97 000

Remarks: Other bearings are available. Please contact NSK for additional information.

Super-TF™ Four-Row Cylindrical Roller Bearings—STF-RV stud-type (Fig.2)

Bearing Numbers	Boundary Dimensions (mm)					Basic Load Ratings (kN)	
	d	D	B	C_2	F_w	C_r	C_{0r}
STF800RV1014g	800	1 080	700	700	878	19 200	55 000
STF1270RV1612g	1 270	1 602	850	850	1 350	32 000	103 000
STF1300RV1612g	1 300	1 655	890	880	1 391	34 000	110 500
STF1348RV1711g	1 348.95	1 745	1 010	1 000	1 466	42 500	134 000

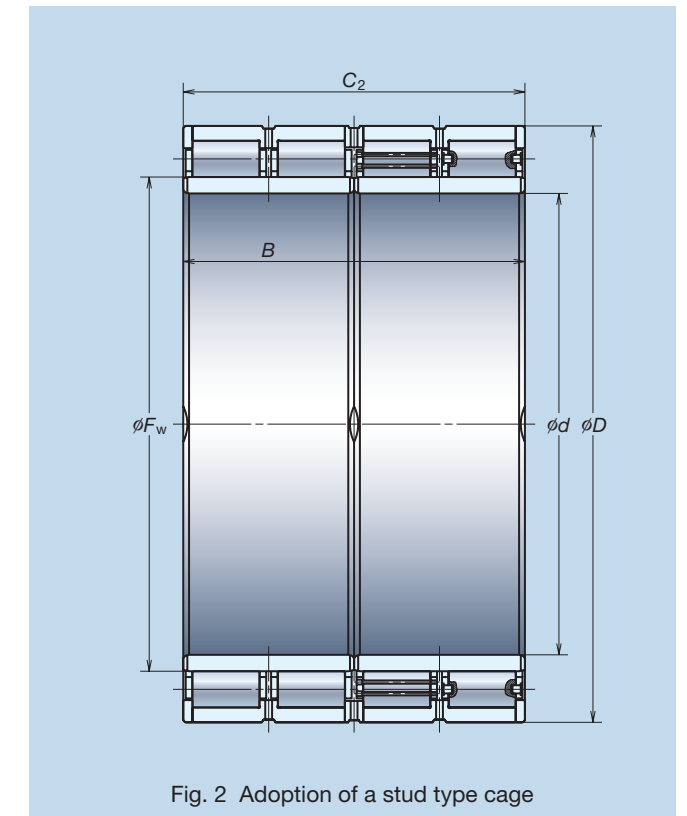
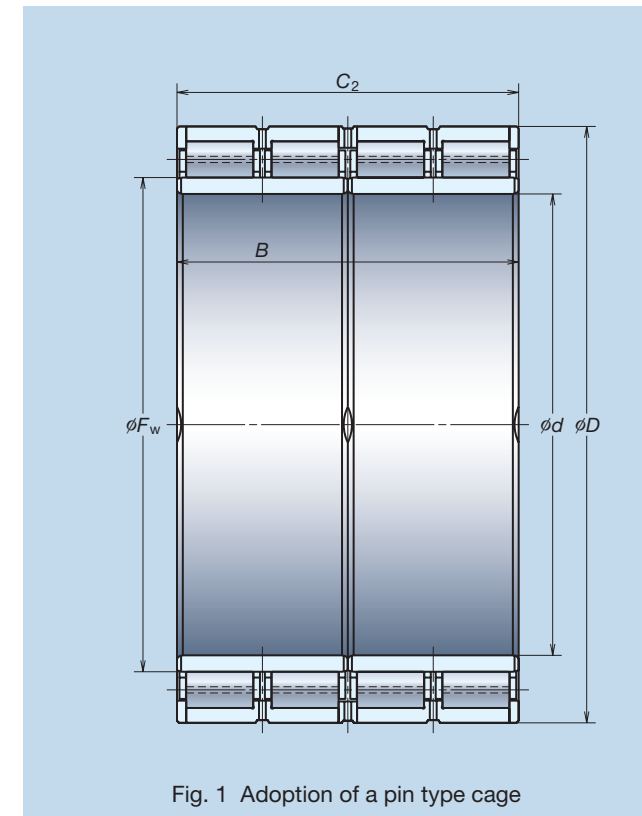

Remarks: The specification of oil mist fitting and O-rings on outer rings are available when requested.

Worldwide Sales Offices

NSK Ltd. - Headquarters, Tokyo, Japan INDUSTRIAL MACHINERY BEARINGS DIVISION-HEADQUARTERS AFTERMARKET BUSINESS DIVISION-HEADQUARTERS AUTOMOTIVE BUSINESS DIVISION-HEADQUARTERS NEEDLE ROLLER BEARINGS STRATEGIC DIVISION-HEADQUARTERS PRECISION MACHINERY & PARTS DIVISION-HEADQUARTERS	www.nsk.com tel: 03-3779-7227 tel: 03-3779-8893 tel: 03-3779-7189 tel: 03-3779-7288 tel: 03-3779-7163	Korea: NSK Korea Co., Ltd. Seoul Changwon Plant Malaysia: NSK Bearings (Malaysia) Sdn. Bhd. Kuala Lumpur NSK Micro Precision (M) Sdn. Bhd. Malaysia Plant New Zealand: NSK New Zealand Ltd. Auckland Philippines: NSK Representative Office Manila Singapore: NSK International (Singapore) Pte Ltd. Singapore NSK Singapore (Pte) Ltd.	www.kr.nsk.com tel: 02-3287-0300 tel: 055-287-6001 www.my.nsk.com tel: 03-7803-8859 www.my.nsk.com tel: 03-8961-6288 www.nsk-rhp.co.nz tel: 09-276-4992 tel: 02-759-6246 www.nsk-singapore.com.sg tel: 65-6273-0357 tel: 65-6278-1711	Industria Cuscinetti S.p.A. Torino Plant Netherlands: NSK European Distribution Centre B.V. Tilburg Poland: NSK Europe Ltd. Warsaw Liaison Office Warsaw Liaison NSK Bearings Polska S.A. Kielce NSK European Technology Center, Kielce NSK Steering Systems Europe (Polska) Walbrzych Spain: NSK Spain S.A. Barcelona Turkey: NSK Bearings Middle East Trading Co., Ltd. Istanbul United Kingdom: NSK Bearings Europe Ltd. Peterlee Plant NSK European Technology Centre Newark NSK UK Ltd. Newark NSK Precision UK Ltd. Newark NSK Steering Systems Europe Ltd. Coventry	tel: 0119824811 tel: 013-4647647 tel: 022-645-1525, 1526 tel: 041-367-0505 tel: 041-366-5812 tel: 074-664-4101 tel: 093-289-27-63 tel: 0216-355-0398 tel: 0191-586-6111 tel: 01636-605123 tel: 01636-605123 tel: 01636-605123 tel: 01636-605123 tel: 024-76-588588
Africa South Africa: NSK South Africa (Pty) Ltd. Johannesburg Asia and Oceania Australia: NSK Australia Pty. Ltd. Melbourne China: NSK Hong Kong Ltd. Hong Kong Kunshan NSK Co., Ltd. Kunshan Plant Changshu NSK Needle Bearing Co., Ltd. Jiangsu Plant Guizhou HS NSK Bearings Co., Ltd. Anshun Plant NSK Steering Systems Dongguan Co., Ltd. Dongguan Plant Zhangjiagang NSK Precision Machinery Co., Ltd. Jiangsu Plant Timken-NSK Bearings (Suzhou) Co., Ltd. Jiangsu Plant NSK China Technology Center Jiangsu NSK (Shanghai) Trading Co., Ltd. Shanghai NSK Representative Offices Beijing Guangzhou Anshun Chengdu Shenzhen Changchun NSK (China) Investment Co., Ltd. Shanghai India: Rane NSK Steering Systems Ltd. Chennai NSK Ltd. India Blanch Office Chennai Gurgaon Indonesia: PT. NSK Bearings Manufacturing Indonesia Jakarta PT. NSK Indonesia Jakarta	www.au.nsk.com tel: 03-9764-8302 tel: 2739-9933 tel: 0512-5771-5654 tel: 0512-5230-1111 tel: 0853-3522332 tel: 0769-262-0960 tel: 0512-5867-6496 tel: 0512-6665-5666 tel: 0512-5771-5654 tel: 021-6235-0198 www.nsk.com.cn tel: 010-6590-8161 tel: 020-3786-4833 tel: 0853-3522522 tel: 028-8661-4200 tel: 0755-25904886 tel: 0431-8988682 tel: 021-6235-0198 tel: 044-274-66002 tel: 044-2446-6862 tel: 124-4104530 tel: 021-898-0155 tel: 021-252-3458	Vietnam: NSK Representative Office Hanoi Ho Chi Minh City Europe NSK Europe Ltd. (European Headquarters) Maidenhead, U.K. France: NSK France S.A.S Paris Germany: NSK Deutschland GmbH Düsseldorf NSK Precision Europe GmbH Düsseldorf NSK Steering Systems Europe Ltd. Stuttgart Neueweg Fertigung GmbH Munderkingen Italy: NSK Italia S.p.A. Milano	www.eu.nsk.com tel: 01628-509800 tel: 04-935-1269 tel: 08-822-7907 tel: 02-6412-150 tel: 038-454010-454016 tel: 038-522-343-350 tel: 038-454631-454633 tel: 01-30-57-39-39 tel: 02102-481-0 tel: 02102-481-0 tel: 0771-79082-277 tel: 07393-540 tel: 02-995-19-1	North and South America NSK Americas, Inc. (American Headquarters) Ann Arbor Argentina: NSK Argentina SRL Buenos Aires Brazil: NSK Brasil Ltda. São Paulo Canada: NSK Canada Inc. Toronto Mexico: NSK Rodamientos Mexicana, S.A. de C.V. Mexico City United States of America: NSK Corporation Ann Arbor NSK American Technology Center Ann Arbor NSK Precision America, Inc. Franklin NSK Steering Systems America, Inc. Bennington, Vermont NSK Latin America, Inc. Miami	tel: 734-913-7500 tel: 11-4704-5100 tel: 011-3269-4786 www.br.nsk.com tel: 011-3269-4786 www.ca.nsk.com tel: 905-890-0740 www.mx.nsk.com tel: 55-5390-4312 www.us.nsk.com tel: 734-913-7500 tel: 734-913-7500 tel: 734-913-7500 www.npa.nsk.com tel: 317-738-5000 www.nssa.nsk.com tel: 802-442-5448 www.la.nsk.com tel: 305-477-0605

NSK Ltd. has a basic policy not to export any products or technology designated as controlled items by export-related laws. When exporting the products in this brochure, the laws of the exporting country must be observed. Specifications are subject to change without notice and without any obligation on the part of the manufacturer. Every care has been taken to ensure the accuracy of the data contained in this brochure, but no liability can be accepted for any loss or damage suffered through errors or omissions. We will gratefully acknowledge any additions or corrections.

For more information about NSK products, please contact: _____



Printed on 100% recycled paper.